



**MITSUBISHI  
ELECTRIC**  
*Changes for the Better*

**M**itsubishi  
**E**lectric  
**Q**uality

**Wrap Yourself in Comfort and Quiet  
Eco-conscious Technologies from Japan**

**Air to Water Catalogue**

**2026**



# Environmental Sustainability Vision 2050

## Environmental Declaration

Protect the air, land, and water with our hearts and technologies to sustain a better future for all.



## Environmental Sustainability Vision 2050

To solve various factors that lead to environment issues, the Mitsubishi Electric Group shall unite the wishes of each and every person, and strive to create new value for a sustainable future.

## Three Environmental Action Guidelines

1

Apply diverse technologies in wide-ranging business areas to solve environmental issues

2

Challenge to develop business innovations for future generations

3

Publicize and share new values and lifestyles

## Key Initiatives

- Climate Change Measures
- Resource Circulation
- Live in Harmony with Nature
- Long-term Activities
- Innovation
- Nurturing Human Resources
- Understanding Needs
- Co-create and Disseminate New Values
- Live in Harmony with the Region

Heat pump technology inspires Mitsubishi Electric to design air conditioners that harmonize comfort and ecology.

Heat Pump Principle (When Heating)  
<Case of COP 5.0>

Refrigerant and Heat Circulation

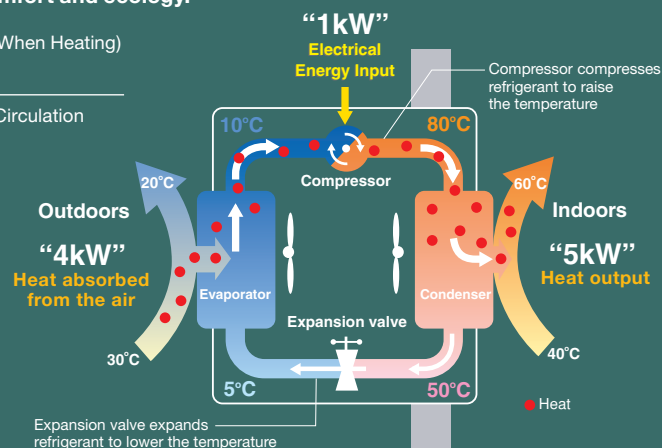



## Mitsubishi Electric takes on the challenge of creating new value and contribute to a sustainable future in order to solve various environmental problems.

### Preventing Global Warming

Mitsubishi Electric is actively introducing R32 refrigerant which has a global warming potential approximately 1/3 that of R410A refrigerant. Not only by shifting from R410A to R32 but by decreasing the diameter of refrigerant piping, we are also striving to reduce the amount of refrigerant usage. Through these activities, we have achieved significant reduction in CO<sub>2</sub> equivalent amount compared to conventional models and realised minimizing the negative impact to the environment more than ever.

#### Reducing the amount of refrigerant usage

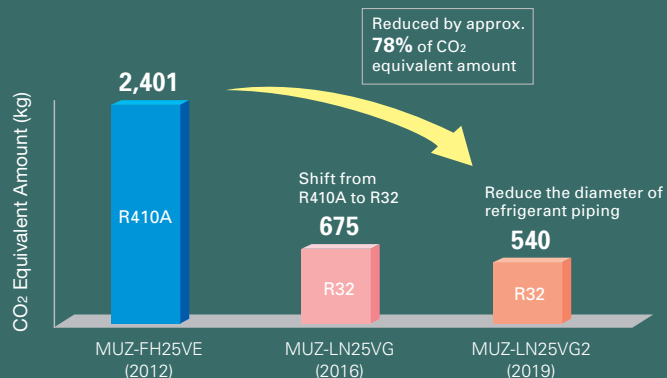

\* reduction rate differs model by model.

### Effective use of materials (Reduce & Recycle)

1. Accelerating the downsizing technology to reduce material use while balancing energy saving performance.
2. Designing products that are easy to separate and recycle.
3. All models are designed for WEEE and RoHS (II) compliance.\*

\*WEEE and RoHS directive: The Waste Electrical and Electronic Equipment (WEEE) Directive is a recycling directive for this type of equipment, while the Restrictions of Hazardous Substances (RoHS) Directive is an EU directive restricting the use of ten specified substances in electronic and electrical devices. In the EU, it is no longer possible (from July 2019) to sell products containing any of the ten substances.

### Balancing comfort and ecology

Mitsubishi Electric develops technologies to balance comfort and ecology, achieving greater efficiency in heat pump operation.

	Comfort	Ecology
<b>1. Inverter</b>	Faster start-up and more stable indoor temperature than non-inverter units.	Fewer On/Off operations than with non-inverter, saving energy.
<b>2. 3D i-see Sensor</b>	Since the positions of people can be detected, airflow can be set to personal taste, such as in airflow path or protected from the wind. The ability to adjust to individual preferences realizes more comfortable air conditioning.	Since the number of people in a room can be detected, energy-saving operation is adjusted or the power is turned off automatically. Efficient air conditioning with less waste is realized.
<b>3. Flash Injection</b>	Achieves high heating capacity even at low temperatures, plus faster start-up compared to conventional inverters.	Expands heat pump heating system to the cold regions to replace combustion heaters.
<b>4. Dual Barrier Coating Dual Barrier Material</b>	Prevents the indoor unit from getting dirty, delivering you clean air.	Keeping the inside of air conditioner clean leads to efficient operation and energy saving.

# CONTENTS



<b>LINE-UP &amp; FEATURES .....</b>	<b>05-27</b>
<b>ECODAN GEODAN .....</b>	<b>28-30</b>
<b>ECODAN MULTI COMFORT .....</b>	<b>31-36</b>
<b>ECODAN MULTI LIGHT .....</b>	<b>37-40</b>
<b>ECODAN CITY MULTI .....</b>	<b>41-44</b>
<b>SPECIFICATION .....</b>	<b>45-58</b>
<b>REFRIGERANT AMOUNT .....</b>	<b>59</b>
<b>DIMENSIONAL .....</b>	<b>61-69</b>
<b>TECHNICAL INFORMATION .....</b>	<b>71-74</b>

# AIR TO WATER



## SELECTION

Choose the series that best matches the building layout.

Excellent ecodan's heating performance, even at low outdoor temperature!







R32

### E-GEN INDOOR UNIT

Hydrobox, Cylinder unit



### OUTDOOR UNIT

Split type	Small capacity (Under 5kW)*	Medium capacity (6kW–14kW)*
		 PUZ-SHWM80/100/120/140
		 PUZ-SWM80/100/120/140
<b>Eco Inverter</b>	 SUZ-SWM40VA2 SUZ-SHWM40VAH	 SUZ-SWM60VA2 SUZ-SWM80VA(H)2/SUZ-SWM100VA(H) SUZ-SHWM60VAH

\*Rated capacity is at conditions A2W35. (according to EN14511)

R410A

### E-GEN INDOOR UNIT

Hydrobox



### OUTDOOR UNIT

Split type

Large capacity  
(≥16kW)\*



PUHZ-SHW230



PUHZ-SW160/200

\*Rated capacity is at conditions A2W35. (according to EN14511)

### INDOOR UNIT

Hydrobox, Cylinder unit



### OUTDOOR UNIT

R290



PUZ-W290/115/140V/YAA-W

R32



PUZ-HWM140



PUZ-WM50



PUZ-WM60/85/112

### Other ATW-related system

PUMY + ecodan

R410A



PUMY-P112/125/140

PXZ + ecodan

R32



PXZ-4F75VG

PXZ-5F85VG

PXZ + DHW Tank

R32



EST-20-V1

ecodan geodan

R32



EHGT17D-YM9ED

# New Eco-design Directive

## What is the ErP Directive?

The Eco-design Directive for Energy-related Products (ErP Directive) established a framework to set mandatory standards for ErPs sold in the European Union (EU). The ErP Directive introduces new energy efficiency ratings across various product categories. It affects how products such as computers, vacuum cleaners, boilers and even windows are classified in terms of environmental performance. Labelling regulations that apply to our ATW heat pumps came into effect from September 26, 2015, and then revised from September 26, 2019.

## New energy label and measurements

Under directive 2009/125/EC, ATW heat pumps of up to 70kW are required to show their heating efficiency on the energy label. The purpose of the energy label is to inform customers about the energy efficiency of a heating unit. The efficiency for space heating is ranked from A+++ to D (from September 2019). In the case of domestic hot water, it is from A+ to F (from September 2019).

### Product label

This label is for individual heating units, such as an ecodan heat pump. Typically, the space heater label is used for ecodan systems with a hydro box, and the combination heater label is used for ecodan systems with a cylinder unit.

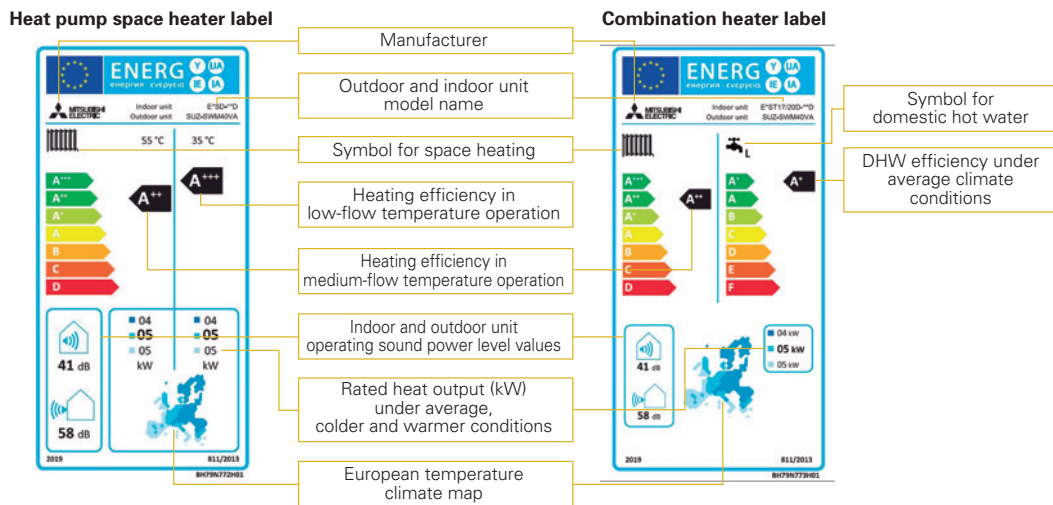

These labels are delivered with all ecodan outdoor units.

## What is the package label?

A heating system can use several energy-related products, such as a controller or solar thermal system. Therefore, a label showing the efficiency of the total heating system is required. The category range is defined from A+++ to G.

Creating the package label is the responsibility of the installers and distributors. A useful tool on the Mitsubishi Electric website is available to easily create the labels for ecodan products and controllers.

<http://erp.mitsubishielectric.eu/erp/options>

### Package label

This label is for heating systems that use several energy-related products, such as a controller or a solar thermal system.

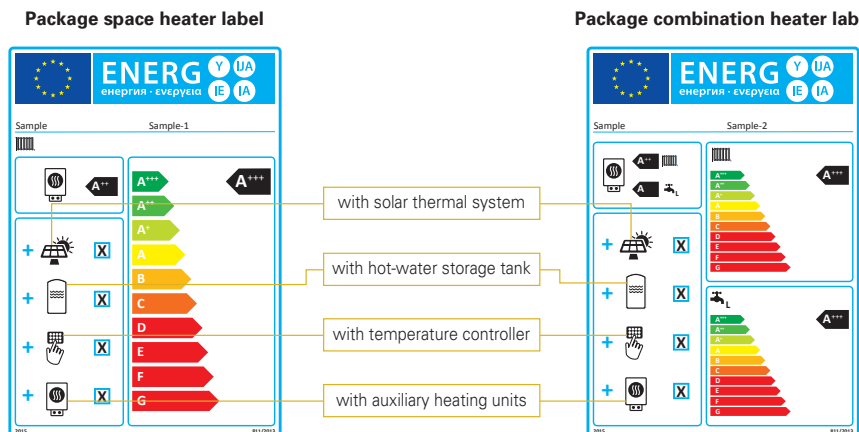

Customised package labels including ecodan heat pumps and the FTC6 controller can be created on the Mitsubishi Electric website.

# NEW R290 PUZ-WZ series

## Wider Line-up

New PUZ-WZ series covers a large capacity range with same chassis as small capacity models and can be adapted to old big houses to replace traditional combustion heating system. Large capacity zone and 3 models can satisfy each customers needs.



Model name		4	5	6	7	8	9	10	11	12	13	14
New	PUZ-WZ-W*1						9		11.5			14

\*1. -W model is designed to maintain high heating capacity in A2 and A7.

## High Energy Efficiency

All models have achieved the "Class A+++" for SCOP at low temperature. SCOP has been improved to achieve further energy saving, contributing to users' energy cost reduction.

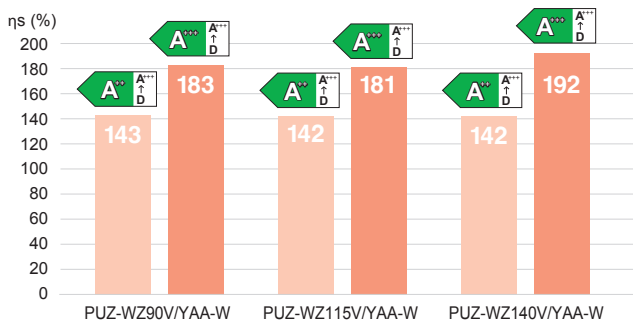

\*ηs values are under reversible operation. ■ Average climate water outlet 55°C ■ Average climate water outlet 35°C

## 75°C Max. Flow Temperature

This new model extends the guaranteed operation range to -25°C ambient temperature, while utilizing the refrigerant properties of R290 to efficiently achieve higher hot water temperatures. It provides high-temperature hot water at 75°C down to -15°C ambient temperature. This allows PUZ-WZ heat pump to be an alternative solution to conventional fossil boilers.

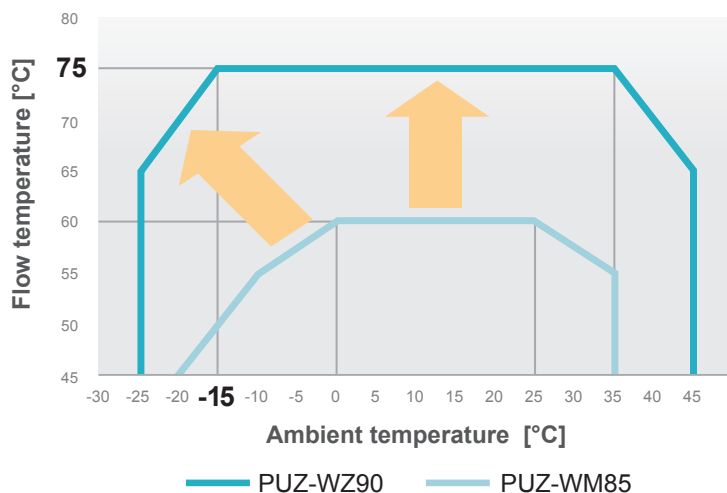

## Quiet Comfort

Reinforced soundproof structure reduces compressor noise, achieving lower sound level than current model. The gapless structure ensures sealing and noise suppression by covering the compressor's base and rubber foot. This enables flexible installation in dense residential areas.

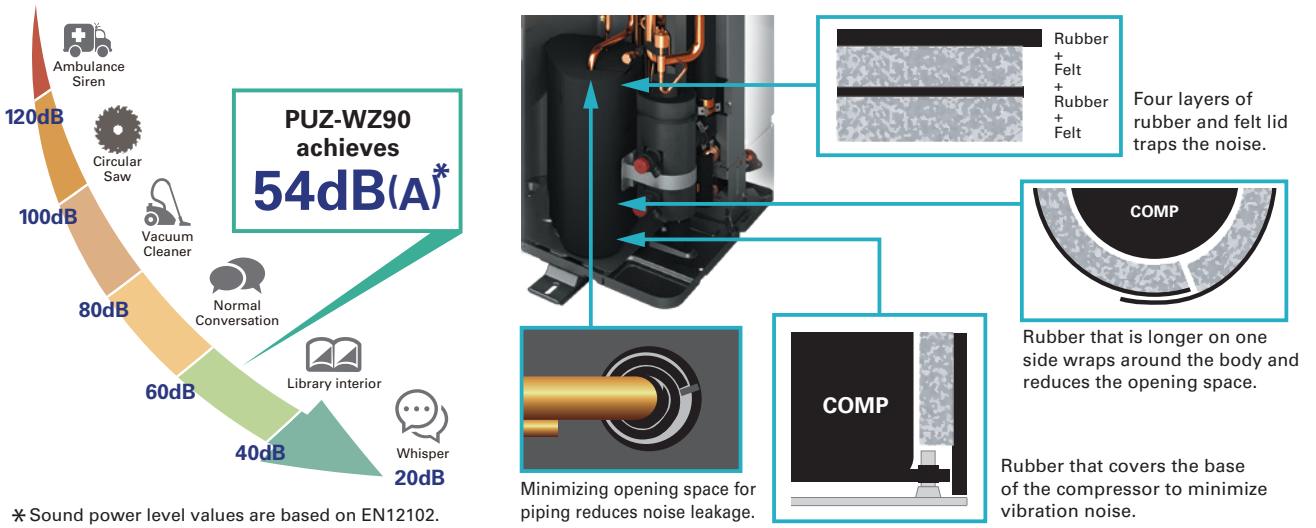

## Easy Maintenance – PCB with Explosion Proof Relay

New PCB with explosion-proof relay make the service and maintenance easy. Thanks to this relay, the space of the enclosed box can be reduced. This design eliminates the need for installers to unscrew the box to access the PCB, saving both time and effort. In addition, this allows the PCB to be relocated to the machinery room side. By installing the PCB in the machinery room, additional space is secured for extra PCBs or components, realizing bigger capacity and 3-phase models.

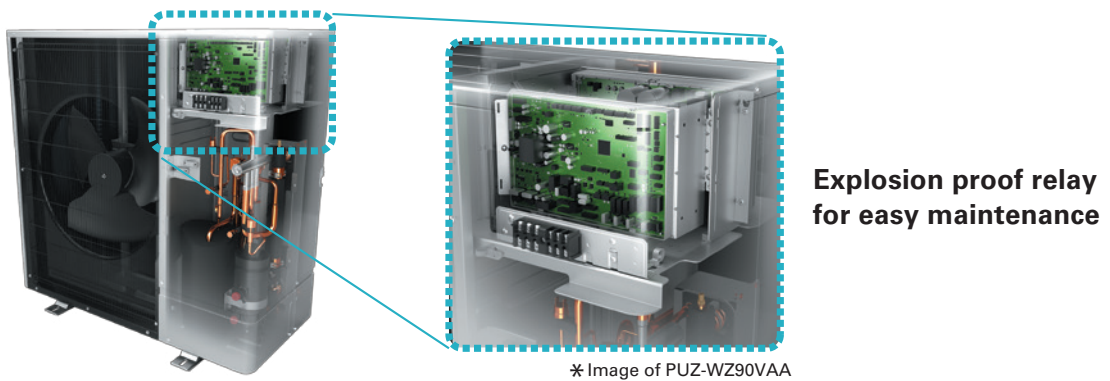

## Eco-friendly - Refrigerant Saving

New PUZ-WZ models adapted a heat exchanger with a small diameter piping. The smaller piping diameter enables wider capacity without increasing the refrigerant amount and imposing additional installation constraints. Refrigerant saving is also contribute to Eco-friendly product. By reduction of the refrigerant amount, we have achieved the reduction in greenhouse gas emissions.

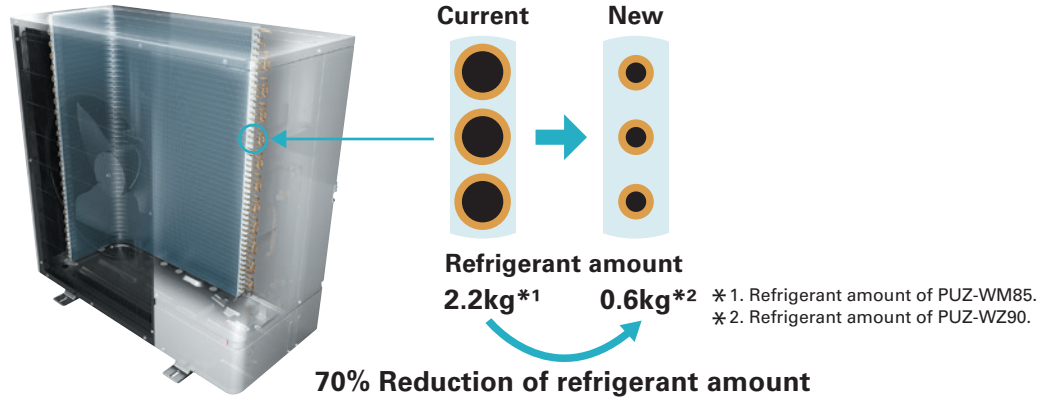

## Maintenance Free - AAV

New PUZ-WZ adopted a new integrated AAV/PRV to improve maintainability and energy efficiency. Auto Air Vent(AAV) and Pressure Relief Valve(PRV) are installed in the water circuit to prevent refrigerant leakage into the room. Cyclone gas-liquid separation improves maintainability and energy efficiency.

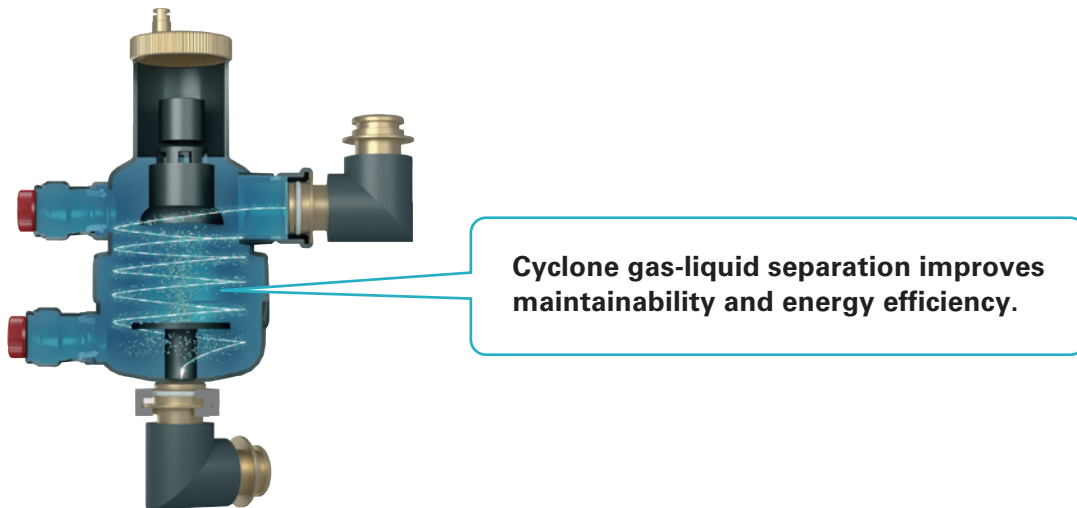

## Water Piping Arrangement

The improved positioning of the water piping makes installation easier. The fixed water nozzle, which can be adjusted with just a single wrench, simplifies installation and reduces the risk of water leakage and piping restriction.

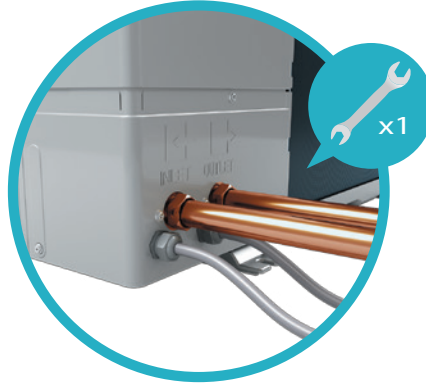

**Easy installation with one spanner.**

## Electric Cable Position Arrangement

The electrical wiring can be accessed from the back of the outdoor unit. This not only improves the appearance but also enhances the serviceability.

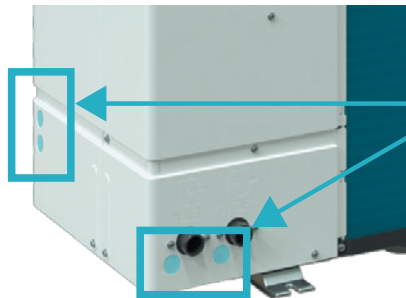

**Two accesable points of electric cables on side and back.**

## Environmentally-friendly Refrigerant R290

PUZ-WZ series is outdoor unit that adopts R290 as new refrigerant. Mitsubishi Electric is contributing to environmental conservation by introducing R290 refrigerant into the heat pumps. Not only the shift to R290, but also the reduction in refrigerant usage has enabled a significant reduction in CO<sub>2</sub> emissions compared to current models. PUZ-WZ series is our first R290 heat pump and we are striving to make a sustainable future.

### Why R290?

It is a natural refrigerant with very low global warming potential (GWP) of 3, about 1/225 compared to R32. The introduction of R290 will greatly contribute to the reduction of greenhouse gas emissions and the improvement of renewable energy ratio efficiency. R290 is also very unique refrigerant with excellent thermal performance, large evaporation latent heat, and refrigerant savings in the system. It supports more comfortable lifestyles.

	R290	R32	R410a
GWP	3	675	2,088

\* These GWP values are based on Regulation (EU) No.517/2014 from IPCC 4th edition.



# R32 Eco Inverter Line-up

## Wider line-up

Standard/Hyper heating/Standard with base heater models are available.

SUZ Series		4kW	6kW	8kW	10kW
Previous	Standard SUZ-SWM	✓	✓	✓	—
	Standard SUZ-SWM	✓	✓	✓	✓
New	Hyper Heating* with base heater SUZ-SHWM	✓	✓	—	—
	Standard with base heater SUZ-SWM	—	—	✓	✓

\*Hyper Heating model: Keep 100% heating capacity at -15°C.



Standard  
SUZ-SWM40/60VA(2)  
Hyper Heating with base heater  
SUZ-SHWM40VAH

Standard  
SUZ-SWM80/100VA(2)  
Hyper Heating with base heater  
SUZ-SHWM60VAH  
Standard with base heater  
SUZ-SWM80/100VAH(2)

## Performance Guaranteed Range Expansion for Max Outlet Water Temperature

New SUZ achieved to keep max outlet water temperature of 60°C in ambient -3°C. Especially Standard 80/100, Hyper Heating 60, and Standard with base heater 80/100 models can also keep max outlet water temperature of 55°C in ambient -15°C.

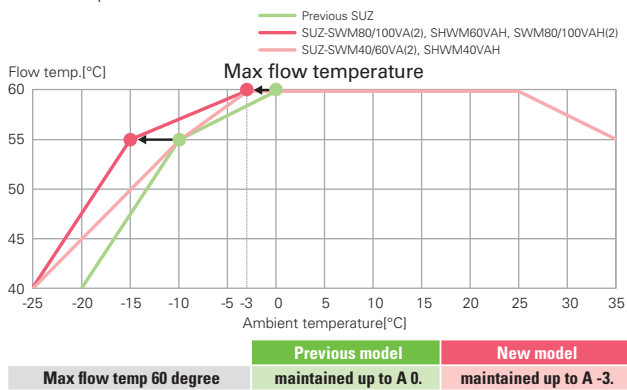

	Previous model	New model
Max flow temp 60 degree	maintained up to A 0.	maintained up to A -3.

## Performance Guaranteed Range Expansion

Performance guaranteed range is extended to -25°C.

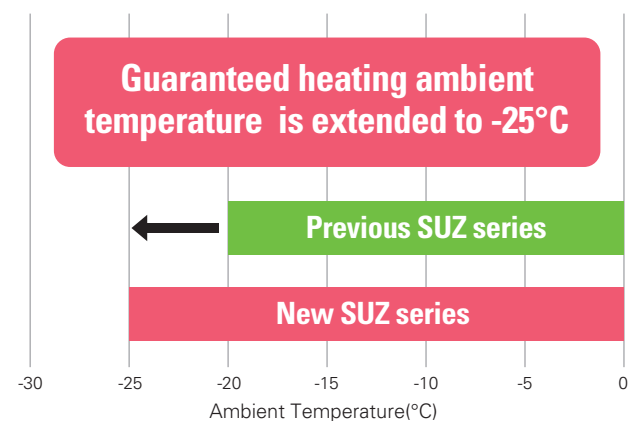

## Quiet mode

Once Quiet mode is activated using the remote controller, SUZ's sound volume becomes lower than normal mode. There are 2 Quiet mode levels in SUZ.

\*Outdoor condition is A-7W35.

\*The cooling and heating capacity may drop if this function is activated.

\*Sound power level values are based on EN12102.

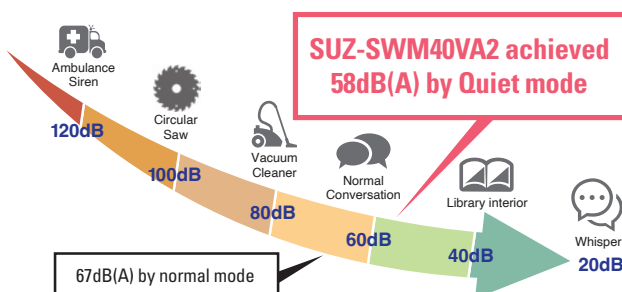

## Improved flexibility for installation

The minimum piping length is reduced to 2m, and the maximum piping length is extended to 46m for SUZ-SWM80/100VA(2), SHWM60VAH, SWM80/100VAH(2)

This enables for flexible installation in any wider properties.

	40	60	80	100
Standard [m]	2-26*	2-26*	2-46*	2-46*
Hyper Heating with base heater [m]	2-26*	2-46*	-	-
Standard with base heater [m]	-	-	2-46*	2-46*

\* For lengths exceeding this, please contact the sales network.

## Blue fin

A special coating is applied to the heat exchanger to improve corrosion toughness.

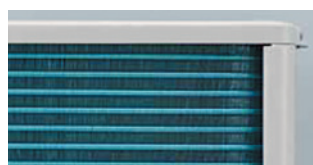

# New PUZ Series

## Great Line-up for Heating and Cooling

Our new flagship PUZ series offers optimized heating and cooling performance and covers both ranges, POWER INVERTER and ZUBADAN.

In addition to space heating and hot water supply, new PUZ series can easily combine with fan coils or underfloor cooling systems to provide with the best thermal comfort also in summer.



Refrigerant	Operation	Series	Power supply	80	100	120	140
R32	Reversible	POWER INVERTER	1Φ230V	●	●	●	●
			3Φ400V	●	●	●	●
		ZUBADAN	1Φ230V	●	●	●	●
			3Φ400V	●	●	●	●

## Further Enhanced Energy Efficiency

### ErP Lot 1 Compliant with Highest Seasonal Space Heating Energy Efficiency Class A+++

All models have achieved the "RANK A+++ (Range from A+++ to D) for SCOP with average climate at low temperature. Thanks to further design optimization, new PUZ is achieving better performance and contributing to reduce energy consumption in a wide range.

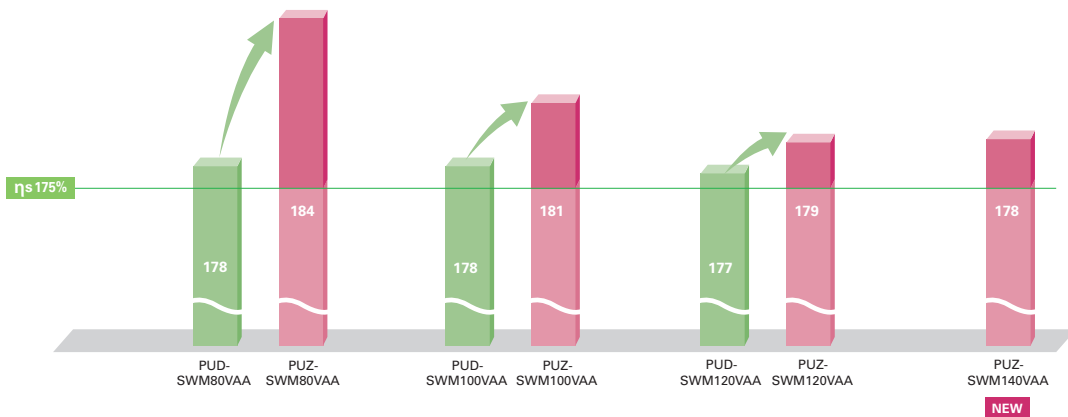

## High Performance

### Guaranteed Heating Operation Range is Extended to -30°C Ambient Temperature

Mitsubishi Electric's unique technology and compressors allow the heat pump to achieve the wider guaranteed heating operation range. 70°C max flow temperature can be maintained down to ambient -7°C for PUZ-SHWM. Even at ambient -30°C, the flow temperature can be kept at 50°C.\*

\*When ΔT is 10°C and the piping length is 15m or less. \*E-generation connection.

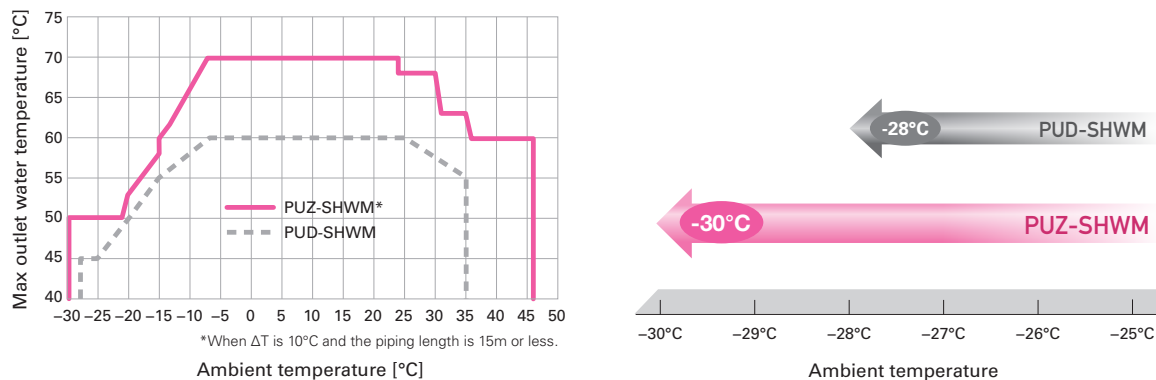

# Quiet Performance

## Improved noise reduction

PUZ achieves quieter operation than previous model with its double anti-vibration structure.

- New 80 models achieved 54dB(A) in PWL.
- New 100-140 models achieved 58dB(A) inPWL.

\*Sound power level values are based on EN12102.

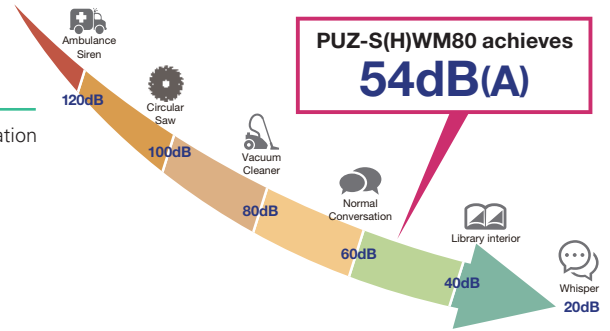

## Quiet Mode

Three-stage quiet mode enables low-noise operation that can be adjusted to meet severe noise conditions.

- \*Values indicated on this chart may differ depending on operating requirements.
- \*Capacity is prioritized during heating in low ambient temperature or cooling in high ambient temperature.
- \*E-generation connection

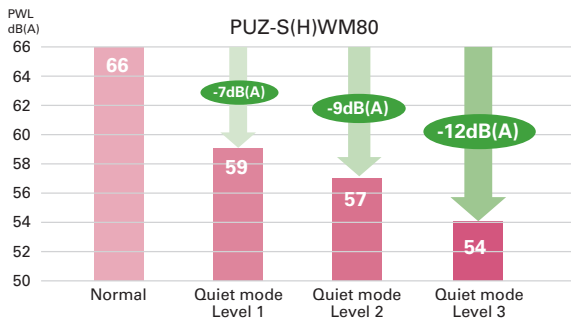

## Double anti-vibration structure

This double structure of an anti-vibration plate and foot rubbers reduces vibration noise to provide high quality performance while minimizing noise.

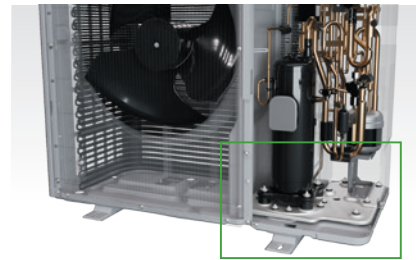

The rate of vibration transmission is greatly reduced by installing stat bolts and foot rubbers on the base and placing an anti-vibration plate on top of it.

In addition, three layers of felt around the compressor absorbs noise. With these unique sound insulation structures, the unit enables less restrictions in residential areas.

# Ease of Installation

**Piping length** Max piping length can be as long as up to 50m\*<sup>1</sup> for more flexible installation. The details are given below.

**Less restrictions** The necessary refrigerant amount has been reduced to a maximum of 2.4kg, which facilitates more flexible installation options.

No additional refrigerant charge (1.8kg) ➔ There is no minimum floor area required to IEC\*<sup>2</sup> safety regulation.  
1.8~2.4kg of refrigerant ➔ Additional refrigerant charge allows up to 50m\*<sup>1</sup> piping length.

\*1 For cooling operation with PUZ-S(H)WM120/140, the max piping length is 30m.  
\*2 The value of installation height (H) is considered following value to comply to IEC60335-2-40: 2018

## Piping length and refrigerant charge amount

New PUZ achieves maximum 50m pipe length. This enables for flexible installation in any wider properties. To keep the maximum amount of refrigerant below 2.4 kg, the upper limit differs depending on heating only and reversible.

	Piping length	Initial amount	Refrigerant amount(kg)	Piping length											
				2-3m	~5m	~10m	~15m	~20m	~25m	~30m	~35m	~40m	~45m	~50m	
Heating only operation	PUZ-S(H)WM 80/100AA	2-50m	1.8kg	Total	1.8							2	2.1	2.2	
				Additional charge	No additional charge							+0.20	+0.30	+0.40	
	PUZ-S(H)WM 120/140AA	2-50m	1.8kg	Total	1.8							2	2.2	2.3	2.4
				Additional charge	No additional charge							+0.20	+0.40	+0.50	+0.60
Heating/Cooling operation	PUZ-S(H)WM 80/100AA	2-50m	1.8kg	Total	1.8	1.9	2	2.1	2.2	2.3	2.4				
				Additional charge	No additional charge	+0.10	+0.20	+0.30	+0.40	+0.50	+0.60				
	PUZ-S(H)WM 120/140AA	2-30m	1.8kg	Total	2.2	2.3	2.4								
				Additional charge	+0.40	+0.50	+0.60								

# Powerful Heating

## Even in Extremely Cold Ambient Temperatures, ZUBADAN can Provide Powerful Heating.

- Our unique flash injection circuit enables max flow temperature of 70°C down to ambient -7°C.\*1
- The guaranteed operating range is extended to -30°C.\*2

\*1. When  $\Delta T$  is 10°C and the piping length is 15m or less.

\*2. In combination with E-generation indoor unit (please refer to combination table).

## Enhanced Heating Performance

Mitsubishi Electric's unique "Flash Injection" circuit achieves remarkably high heating performance. The technology has resulted in an excellent heating capacity rating ambient temperatures as low as -15°C, and the guaranteed heating operation range has been extended to -30°C. Accordingly, the heat-pump units of the ZUBADAN series are perfect for warming houses in the coldest regions.

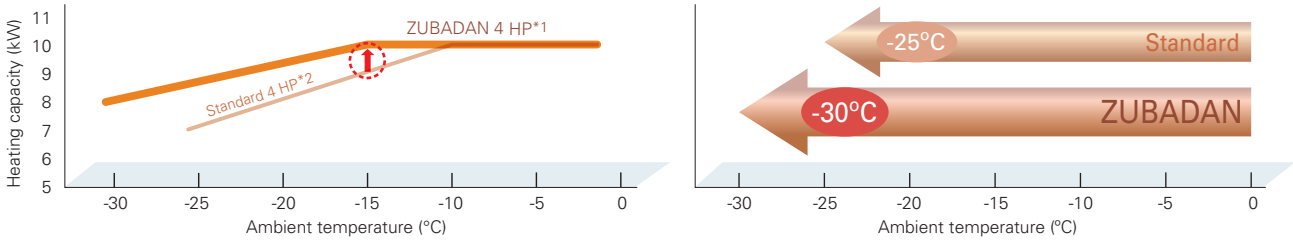

\*At rated condition of 35°C flow temperature

\*1. PUZ-SHWM100V/YAA

\*2. PUZ-SWM100V/YAA

## Flash Injection Technology – The key to high heating performance at low ambient temperatures –

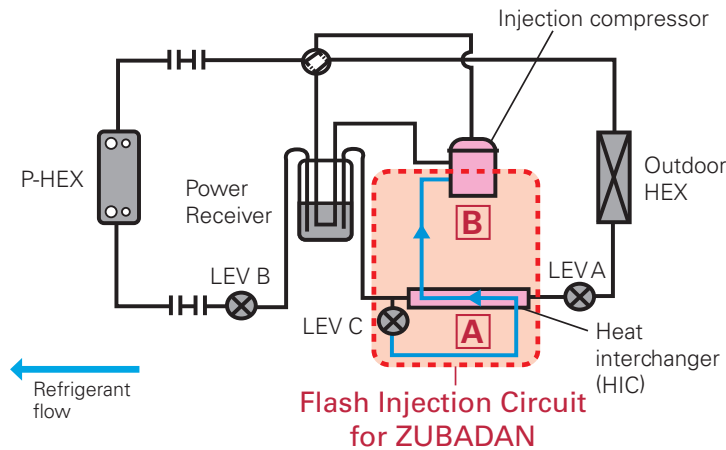

### A Heat Interchanger (HIC)

HIC cross-sectional view

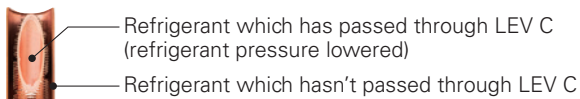

**Purpose:** Transform liquid refrigerant into liquid-gas state

**Effect:** Injection circuit increases energy efficiency

The compressor is subjected to a heavy load when compressing liquid refrigerant, and the result is lower operation efficiency. The addition of HIC supports refrigerant heat exchange at two different pressure levels. The heat-exchange process transforms the injected liquid refrigerant into a gas liquid state, thereby decreasing the load on the compressor during the compression process.

### B Injection Compressor

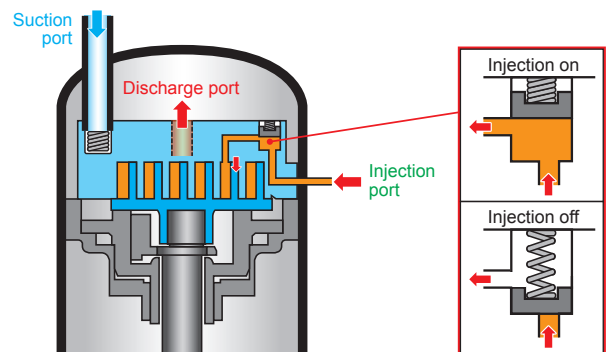

**Purpose:** To increase the volume of refrigerant being circulated

**Effect:** Improves heating capacity at low ambient temperatures, and enables higher outlet temperature adjustment and shorter defrost operation time.

Refrigerant passes from the HIC into the compressor through the injection port. Having two refrigerant inlets makes it possible to raise the volume of refrigerant being circulated when the ambient temperature is low and at the start of heating operation.

# E generation Indoor Unit

## Line-up

ecodan's line-up has many types of indoor units to satisfy diverse customers' needs, requests and local regulations. It includes various size of tank up to 300L, with/without booster heater, with/without an expansion vessel, etc. In addition, reversible hydrobox and cylinder units are available.

### Hydrobox

### Cylinder unit



## New Design

ecodan E generation is now available in a new design. This simpler and more sophisticated new logo unit blends in nicely with any interior design.

### Available Indoor Units

- Packaged or Split type
- Reversible (for heating/cooling) or Heating only model
- With/without booster heater
- With/without expansion vessel
- Cylinder unit has an integrated 170L/200L/300L stainless steel tank
- Hydrobox allows control for domestic hot water with a stand-alone tank (locally supplied)

## All-in-one Compact Indoor Unit

- All-in-one: Key functional components are incorporated
- Compact cylinder unit: 1,400~2,050mm in height
- Compact hydrobox: Only 530x360mm footprint
- Easy installation: Factory fitted pressure relief valve
- Easy service: Relevant parts are located at the front of the unit for easy maintenance
- Easy transport: Handles attached on front and back (cylinder unit)

**NEW** "New" means that these features are only available on the E generation units; all other features are present on both the D and E generation units.

**NEW** Water piping  
Nuts added for improved installation ease

### Hydrobox

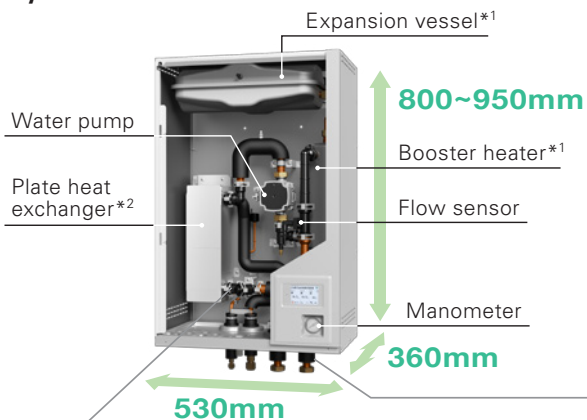

### Cylinder unit

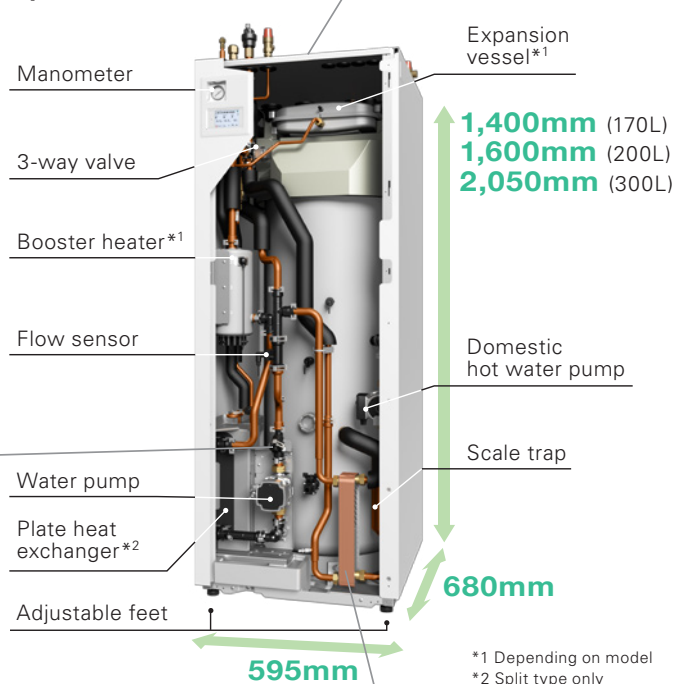

**NEW** Water circuit  
Magnetic filter as standard equipment

### Domestic hot water plate heat exchanger

High efficiency plate heat exchanger offers better performance and allows to use the whole tank volume for DHW compared to coil in tank.

## Easy Installation and Low Maintenance

### Simple Piping Arrangement NEW

All water piping is aligned at the rear side of the unit for easy connection and neat finish. In addition, NUTs are added to improve ease of installation.



### Built-in Drain Pan for Reversible Cylinder Models

Reversible models include a built-in space saving drain pan and the drain socket is positioned at the back of the unit. With use of the adjuster bolt, the outlet height can be higher than 50mm, allowing 5m drainage.

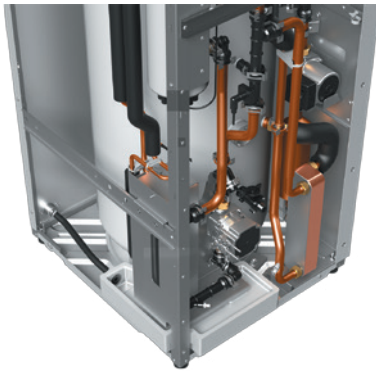

### Hydrobox Piping Arrangement

Through structural innovation related to the space around the pipes, the area where the spanner can be moved has been increased, thus improving pipe work and enabling it to be completed smoothly.

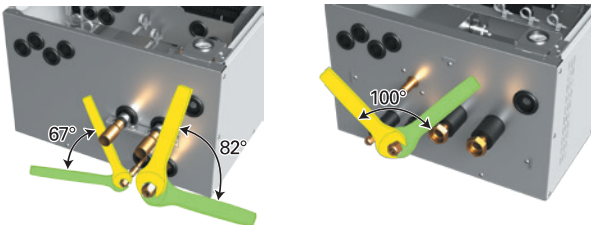

### Easy Adjustment

Adjust bolt capable of 50mm expansion for easy installation on uneven surfaces.

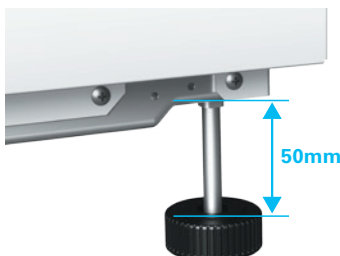

### Improved Quick Start NEW

To start ecodan quickly, initial settings are narrowed down to the essential items and unnecessary settings are skipped automatically. Displaying the system configuration before commissioning helps clarify the basic Dip switch position and prevent resetting. This reduces time needed to complete commissioning.

Sample display of Emitter setting

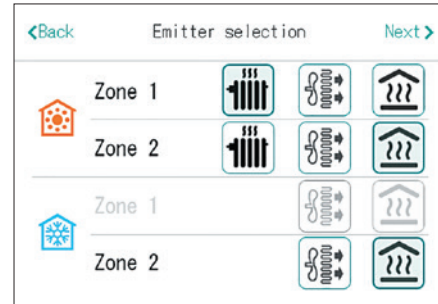

Installers can simply select emitters and use the recommended default values, preventing wrong running mode per zone.

### Operation Data Monitoring

Time, operation mode, flow/return/tank temperature, can be displayed on main remote controller.

Sample display of monitoring setting

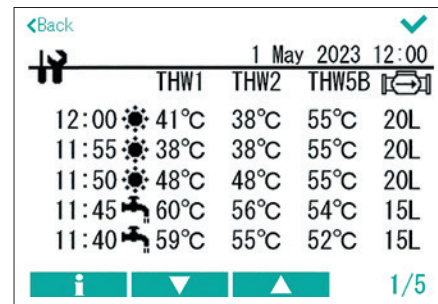

### Minimum Additional Water Required

In average/warmer conditions, minimum additional water is required for outdoor unit. If there is enough water amount inside water pipe, radiator, or underfloor heating, no buffer tank is required.

\*Refer to the indoor unit installation manual for specific outdoor unit models.

### Clean Circuit Water NEW

Magnetic filter is newly added into the strainer. This keeps the water in the circuit clean and prevents clogging and deterioration of pumps and 3 way valves.

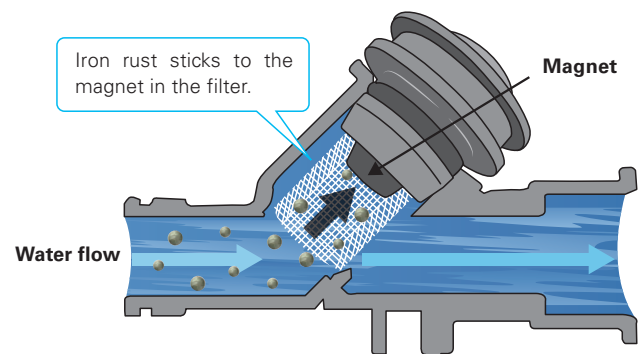

## High Performance

### High Efficiency

With additional thermistor (THW5A),  $\eta_{wh}$  [%] rating is improved 170L and 200L to achieve A+, the highest possible domestic hot water efficiency rank.

Excellent DHW efficiency



	170L	200L	300L
Declared load profile	L	L	XL
Water heating energy efficiency class*	A+	A+	A/A+

\*Range from A+ to F

### Thermistor Position of Cylinder

The thermistor position is selectable allowing the unit to accommodate for different water demands in order to maximise the efficiency of the unit for any size of household or application. Using two thermistors equipped with all sizes of tanks, you can now select the DHW recharge amount from two options (Standard/Large). It helps to accommodate for different water demands in order to maximise the efficiency of the unit for any size of household or application. This mode can be selected from main remote controller.

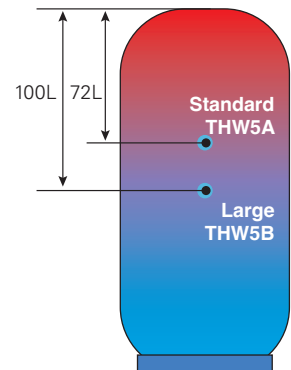

\* In case of 200L tank.

## Unique Technology of ecodan

### 2 Zone Control (for heating/cooling) by Local Supplied Components

#### Improved Simultaneous Control of Two Different Zones



\*microSD logo is a trademark of SD-3C, LLC.

Using ecodan, it is possible to control two different flow temperatures, thereby managing two different heating load requirements. Now, by adding a new mixing control in zone 1 as well as zone 2, the flow temperature can be controlled in both zones, providing more flexible heating operation anywhere in the house. The system can adjust and maintain two flow temperatures when different temperatures are required for different rooms; for example, controlling a flow temperature of 40°C for the bedroom radiators and another flow temperature of 30°C for the living room floor heating. Also, new controller monitors the temperature inside buffer tank and prioritizes using the heat inside the tank to avoid frequent on/off operation when using 2 zone control. This function allows better integration with smart grid or energy management system because the buffer tank can be heated up independently from the zones temperature requests (even for zone 1).

#### ■ Two temperature zones

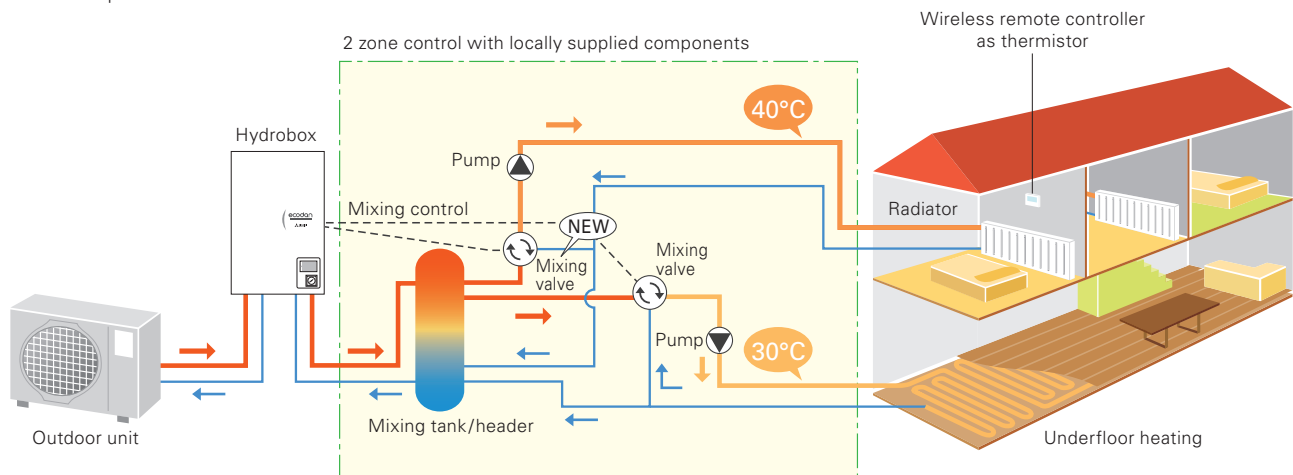

\*Items such as a mixing tank, mixing valves and pumps are not included and need to be purchased locally.

### 2 Zone Kit (Optional)

- You can select from 3 types of pump operations, 1. Fixed speed mode, 2. Fixed pressure mode, 3. Energy saving mode, depending on your preference.
- All-in-one kit: Key functional components are incorporated in 2 zone kit.
- Easy installation: G1 screw type flexi-piping to avoid brazing.
- Compact size: Just to fit on the top of cylinder unit, also wall mountable.



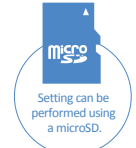

\*microSD logo is a trademark of SD-3C, LLC.

# Auto Adaptation for Heating

## Maximise Energy Savings While Retaining Comfort at All Times

Regarding the relation of flow temperature and unit performance, a drop in the flow temperature improves the coefficient of performance (COP) of the ATW system. This means that energy savings are dramatically affected by controlling the flow temperature in the system.

### Weather compensation curve setting (Example)

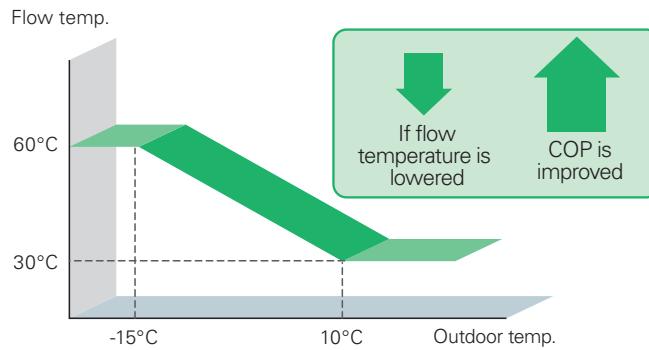

## Automatically Tracks Changes in the Actual Room Temperature and Outdoor Temperature to Adjust flow Temperature Accordingly

Aiming to realise further comfort and energy savings, Mitsubishi Electric has already introduced a revolutionary controller. Auto Adaptation function measures the room temperature and outdoor temperature, and then calculates the required heating capacity for the room. Simply stated, the flow temperature is automatically controlled according to the required heating capacity, while optimal room temperature is maintained at all times, ensuring the appropriate heating capacity and preventing energy from being wasted.

Furthermore, by estimating future changes in room temperature, the system works to prevent unnecessary increases and decreases in the flow temperature. Accordingly, Auto Adaptation maximises both comfort and energy savings without the need for complicated settings.

By introducing improved control logic in our ecodan, we achieved faster heating and more energy saving.

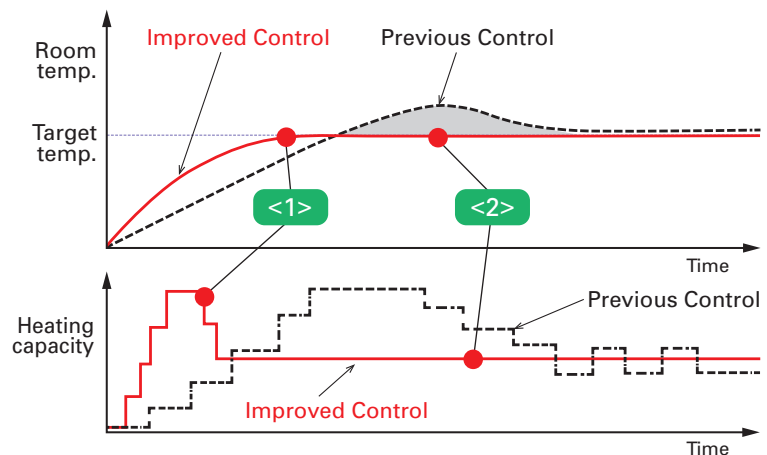

<1> Fast heating with improved accuracy by learning building heat load  
 <2> Energy saving by avoiding over heating and capacity fluctuation with better control response, i.e. control interval and resolution

## Auto Adaptation Improvement NEW

### Mitsubishi Electric's New Auto Adaptation Function Provides Temperature Adjustment that Reflects User Preferences

New Auto Adaptation added manual settings for target temperature compensation based on the building's structure, allowing temperature adjustment according to preferences from Auto/Normal/Slow/Quick. For example, selecting Quick mode allows you to quickly reach the target temperature, thus your room can get warm more quickly. Once the target temperature is reached, the heating capacity is maintained at a constant level, providing energy efficient heating operation. However, in well-insulated houses with underfloor heating emitters, normal or slow mode would be preferred to optimise energy savings and avoid temperature overshoot.

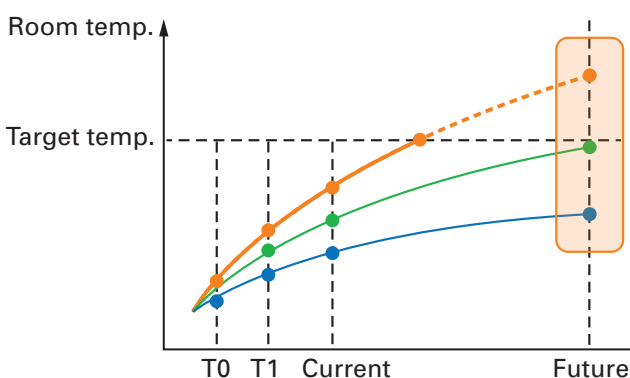

The room temperature at "Future" would be...

\*Without considering the flow temperature control after the target temperature is reached.

- (Quick) **Higher than the target room temp.**
  - ▶ The control works to lower the flow temp. by comparing the actual and estimated room temperature.
- (Normal) **Approximately same as the target room temp.**
  - ▶ The control works to keep the flow temp. by comparing the actual and estimated room temperature.
- (Slow) **Lower than the target room temp.**
  - ▶ The control works to raise the flow temp. by comparing the actual and estimated room temperature.

# Cooling Functions NEW

## Flexible Cooling Control Functions to Suit User's Lifestyle

### Weather compensation curve for cooling

Weather compensation curve for cooling is now available. The target water temperature is determined according to changes in ambient temperature. The new user-controlled cooling curve compensation prevents the heat pump from producing excessive flow temperatures for the primary circuit, maximizing efficiency and reducing running costs. FTC uses information from both an outdoor temperature sensor and a temperature sensor on the primary circuit supply to ensure the heat pump is not producing excessive flow temperatures if the weather conditions do not require it.

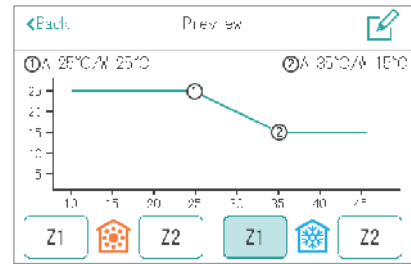

### Auto Change Over (ACO)

Instead of the current manual summer/winter mode adjustment, which determines whether heating operation is permitted (or prohibited) according to the ambient temperature, new Auto Change Over is equipped to automatically switch between heating mode and cooling mode according to the ambient temperature. When the ambient temperature reaches a certain level, the operation automatically switches from heating to cooling or cooling to heating. So, there is no need for manual adjustment, providing more comfortable and stress-free room temperature control.

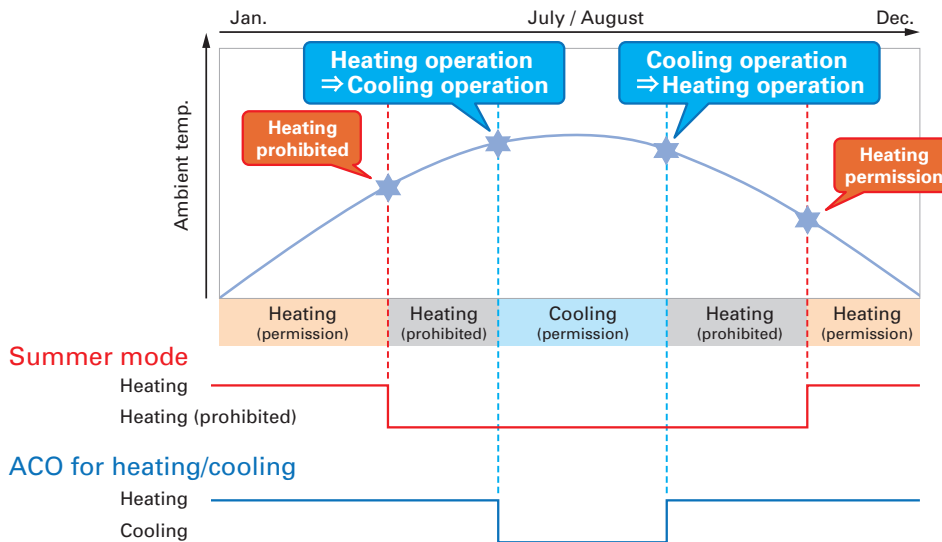

### Forced cooling mode

It is now possible to switch to forced cooling mode with an external input. When input terminal IN13 receives a "cooling operation ON" signal from the external source, the operation mode is forcibly switched to cooling. Auto change over judgment is paused during this time. Local supply or your current thermostat can be used to enable cooling ON/OFF.

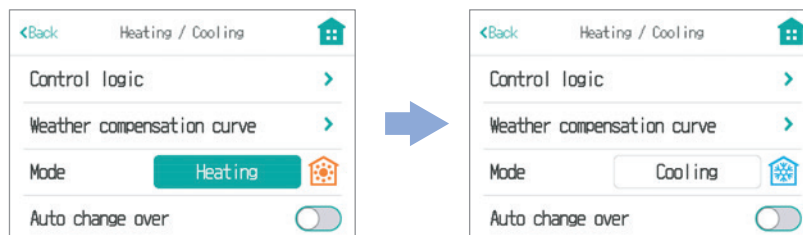

### Cooling lower limit temperature

A new function is available to prevent dew point condensation by forcibly switching the lower temperature limit with an external input. If the water temperature falls below the set value during cooling operation, dew point condensation may occur. Humidity is monitored by a dew point temperature sensor (locally supplied), and when input terminal IN15 receives a signal, the water temperature safety device is activated and the lower limit of the flow temperature is automatically changed. For example, if an external input is received from the sensor when operating at 5°C water flow temperature, the temperature is switched to the lower limit of 20°C, preventing condensation. Cooling target temperature (lower limit) can be set by yourself on remote controller setting screen.

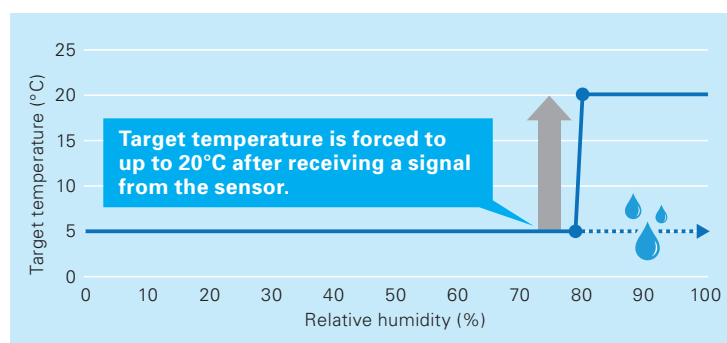

# Multiple Unit Control

## Connect up to 6 Units – Automatic Control of Multiple Units for Bigger Capacity and Better Efficiency

A maximum of 6 units\* can be configured according to the heating/cooling load of the building. The most efficient number of operating units is determined automatically based on heating/cooling load. This enables ecodan to provide optimal room temperature control, and thus superior comfort for room occupants. Also incorporated is a rotation function that enables each unit to run for an equal time period. If one of the units malfunctions when using the Multiple Unit Control, another unit can be automatically operated for back-up, thereby preventing the system operation from stopping completely.

\*Only same models (same capacity) can be used.

### Multiple unit control

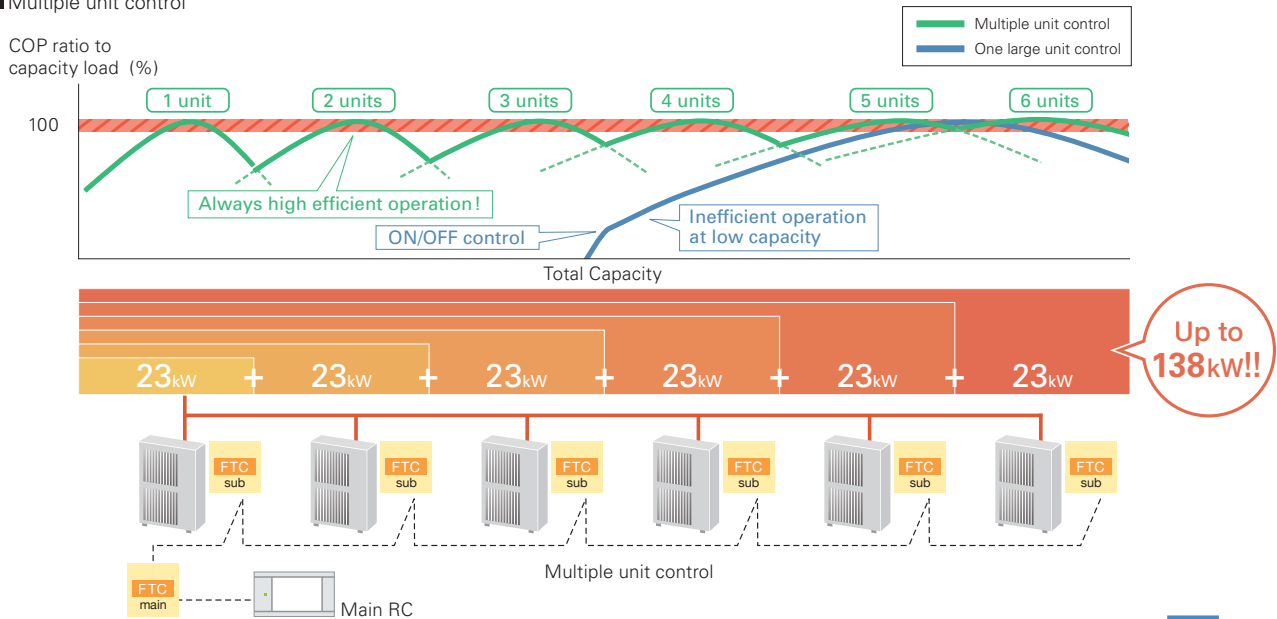

## Intelligent Hybrid Control (boiler interlock)

### An Existing Boiler Can Be Used for Extra Heating Capacity in an Efficient Way



\*microSD logo is a trademark of SD-3C, LLC.

The flexibility of ecodan's intelligent control allows the system to be combined with the boiler currently in use. Additionally, this control can judge which heating source to use either ecodan or the existing boiler, based on various conditions\*.

In the event of one heating unit not working due to some unforeseen problem, the other heating system can be used as a back-up, thereby preventing the heating system operation from stopping completely.

\*Please see below "Heat source switchover".

### Intelligent system combining a boiler with ecodan

#### Intelligent boiler interlock system

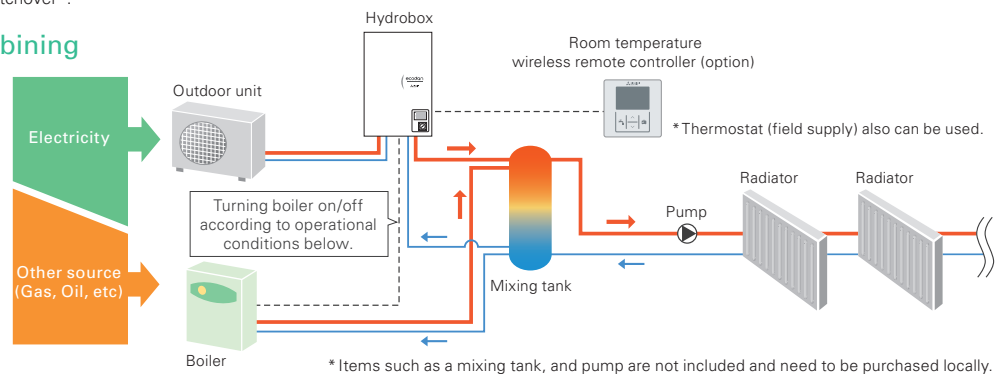

### Heat source switchover - Choose appropriate system based on needs

#### 4 types of heat source switchover logic

- ① Switchover based on actual outdoor temperature
  - Heat source switchover occurs when the outdoor temperature drops below a pre-set temperature.
- ② Switchover based on running cost
  - Heat source switchover occurs by judging optimal operation based on running cost.
  - \*Pre-registration of the energy price of electricity, and gas or oil per 1kWh is necessary.
- ③ Switchover based on CO<sub>2</sub> emission level
  - Heat source switchover occurs to minimise CO<sub>2</sub> emission.
  - \*Pre-registration of CO<sub>2</sub> emission amount from electricity and gas or oil is necessary.
- ④ Switchover can also be activated via external input
  - For example, the peak cut signal from electric power company.

## Smart Grid (SG) Ready Function

In recent years, renewable energy generation has become popular. However, this rapid growing causes the problem of supply and demand gap of electricity. The aim of "SG Ready" is to make the electricity demand response more flexible by creating a uniform interface for the smart grid integration of heat pumps. Air-to-Water units need to be able to change the operation pattern when the signal is received from the Smart Grid Controller.

ecodan Cylinder, Hydrobox and FTC (Flow Temperature Control) have been modified to communicate with Smart Grid Controller.

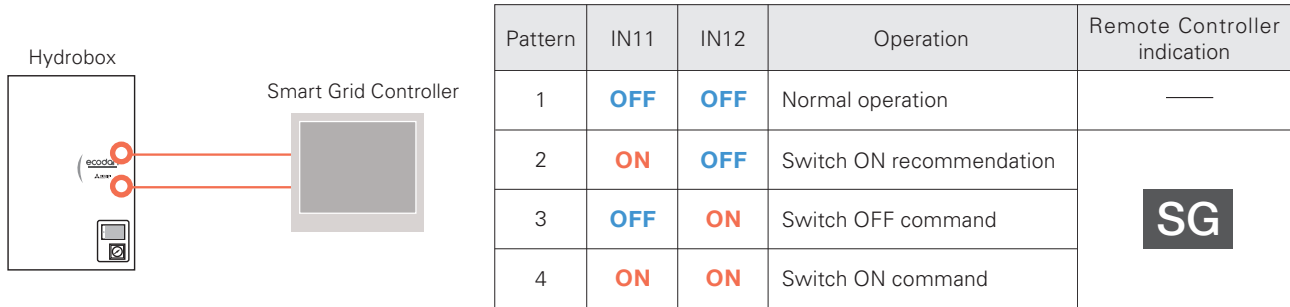

### Pattern 1: Normal operation

When there is no signal from the Smart Grid Controller, DHW and Heating operate according to user settings.

### Pattern 2: Switch ON recommendation

When set to the "Switch ON" recommendation, the target temperature of DHW is increased a specified amount and the heating "Thermo ON" condition range is extended.

### Pattern 3: Switch OFF command

When the "Switch OFF" command is received, both DHW and Heating are turned off.

### Pattern 4: Switch ON command

When the "Switch ON" command is received, the target temperature of DHW is increased to the maximum target temperature and Heating continues.

## Improved Smart Grid Ready Function

SG ready icon on main remote controller indicates that SG ready is active and its setting can be easily operated with main remote controller. Improved SG ready function enables you to choose the target temperature by 1°C steps. Also, when PV manager is interlocked with ecodan and ecodan receives its signal, heat is stored as much as possible while heat pump and/or electric heater is/are operating.

Heat storage in large buffer tank will be made available well when peak cut signal is on. As long as a mixing valve keeps its control, temperature is maintained.

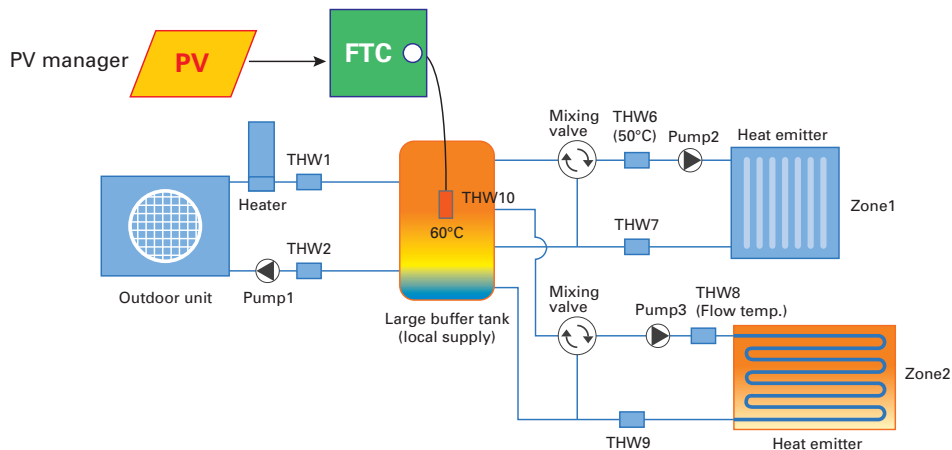
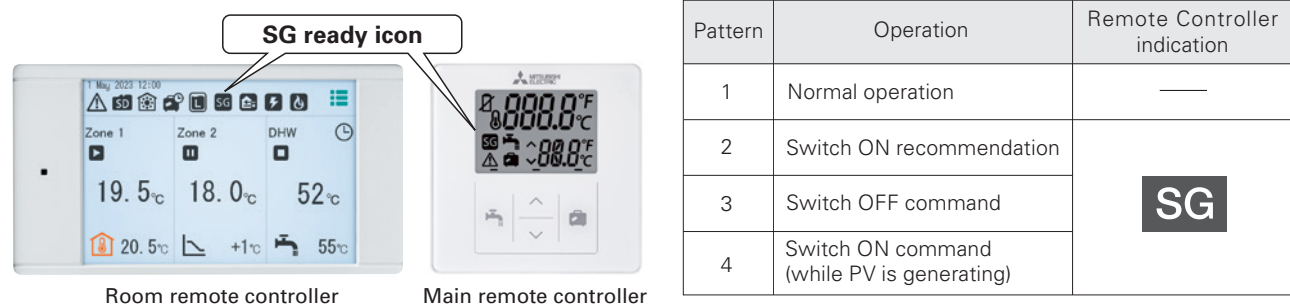

# Main Remote Controller E generation

## Simple User-friendly Controller with New Design

- New design for simple and intuitive operation
- Color display and touch screen for excellent visibility
- Multi-language support (supports 24 languages)
- Wide range of convenient functions in response to user demand

### Function settings

- Energy monitoring
- Two-zone control (cooling and heating)
- Two separate schedules
- Built-in room temperature sensors
- Hybrid control (boiler interlock)
- Floor drying mode
- Weekly timer
- Holiday mode
- Legionella prevention
- Error codes

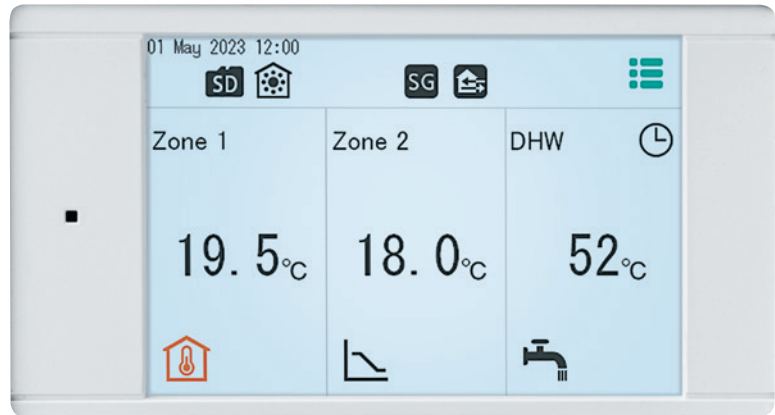

## Display All Necessary Information from the Home Screen

New main remote controller shows all information at a glance on the home screen so that users do not need to spend time looking for the information they want.

2 zone display on 1 screen

New incrementation 0.5°C that gives you more accurate information and comfort.

Schedule is ON

DHW production: ON / OFF

Actual temperature: 19.5°C  
Target temperature: 20.5°C

Recognizable icons & colors

- Heat pump status with direct expression icons
- Control logic with color indication

Running Defrost Quiet mode with level Emergency heating Heating Cooling Not running

## Improved Usability for Intuitive Operation

### - Multiple settings all at once

New main remote controller combines the related 4 settings in one screen to avoid back and forth navigation. This contributes to time savings and comfort as it eliminates the need to confirm in each setting.

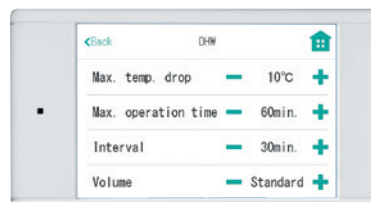

### - Simplified schedule setting

An intuitive schedule setting screen is now adopted, removing the previous complex setting. The timeline is easily cognizable and permission or prohibition of heating and cooling for 2 seasons can be set at once.

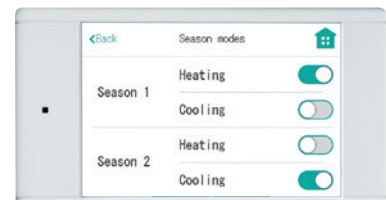
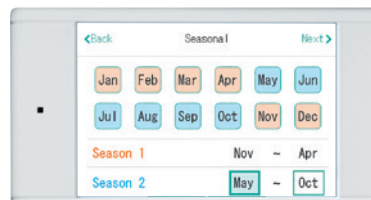

## Customisation to Provide More User Comfort

### - Adjustable backlight brightness in 3 levels

Main remote controller may be removed from the indoor unit and used in a room where it is ordinarily in view of users. The brightness of the screen can now be adjusted in 3 levels to suit the user's preference so as not to disturb their daily life. The screen can be set to turn off when not using the remote controller, or the backlight can be dimmed so that the display is always visible.

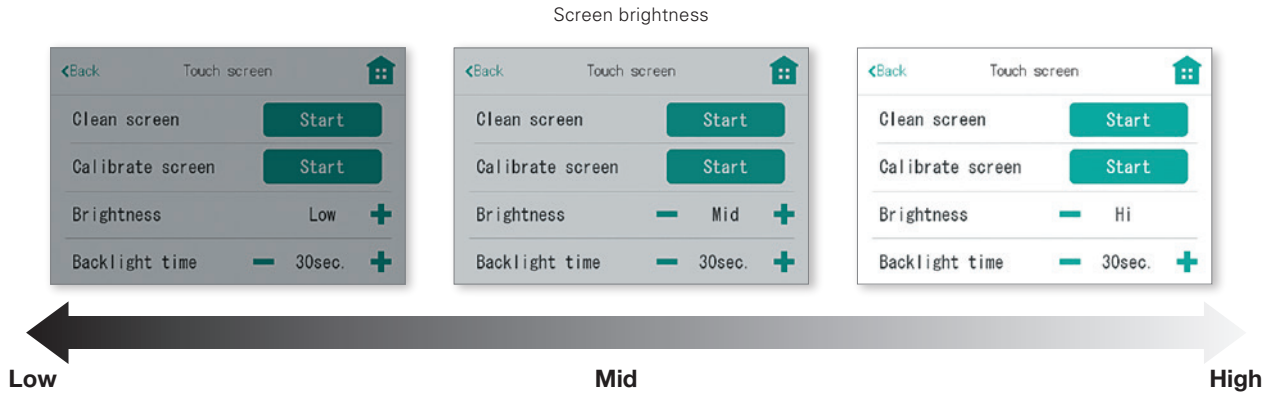

### - Choice of LED

This LED is intended to instantly alert the user to errors. The LED flashes during unit start-up or system errors such as malfunction of the outdoor unit. Previously, the LED was constantly on in operation, but to increase comfort, this new remote controller has a setting to switch off the LED in operation. Regardless of the setting, however, the LED flashes to inform users immediately in case of system errors.



## microSD NEW

### For Easier Settings and Data Logging



\*microSD logo is a trademark of SD-3C, LLC.

The initial setting for ecodan is now simpler than ever before. The special software enables the required initial settings to be saved to a microSD using a personal computer. The system set-up is as easy as moving the microSD from the computer to the microSD slot in the indoor unit. Compared to the previous procedure of inputting settings using the main controller at the installation site, a remarkable reduction in set-up time has been achieved. Thus, it is ideal for busy installers. A microSD is already inserted in the unit.

Hydrobox operation panel

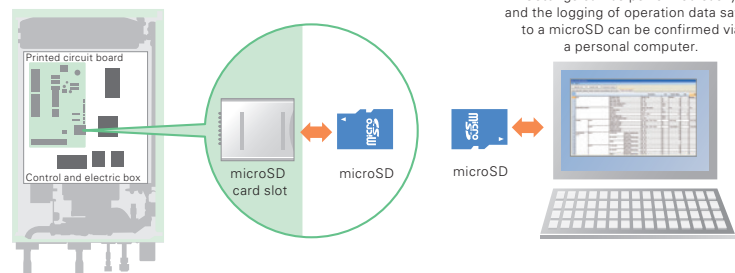

### Items that can be pre-set

Simply copying pre-set data to a microSD, the same settings can input into another unit using the microSD.

- Initial settings (time display, contact number, etc.)
- Heating settings
  - Auto adaptation
  - Weather compensation curve
  - Two different temperature zones (heating and cooling)
- Interlocked boiler operation settings
- Holiday mode settings
- Schedule timer settings
- Domestic hot water settings
- Legionella prevention settings

All items that are set by the main controller can be set via a personal computer.

### Data that can be stored

Operation data up to a month long can be stored on a single microSD.

- Consumed electrical energy
- Delivered energy
- Flow rate
- Operation time
- Defrost time
- Actual temperature
  - Room temperature
  - Flow temperature
  - Return temperature
  - Domestic hot water temperature
  - Outdoor temperature
- Error record
- Input signal

## Wireless Remote Controller (Optional) NEW

### Smart User-friendly Controller with Stylish Design



- Remote control from any room with flexible installation location
- Built-in room temperature sensor; easy to place at various positions to detect the room temperature
- New sleek designed flat panel and touch buttons for intuitive operation
- Easy-to-read LCD screen and big buttons for better usability
- No cabling required thanks to wireless connectivity
- Domestic hot water boost and cancellation function
- Holiday mode settings for up to 72 hours on hourly basis for energy saving with simple operation
- Room temperature is controlled according to the temperature monitored in a selected room
- Up to 8 wireless remote controllers connectable
- Floor-to-floor wireless transmission such as from basement to floor level

### New Screen Display with Touch Buttons

- SG-ready icon added
- Each icon unified with the design of the main remote controller
- An LED light is added to notify users instantly if an error or malfunction occurs

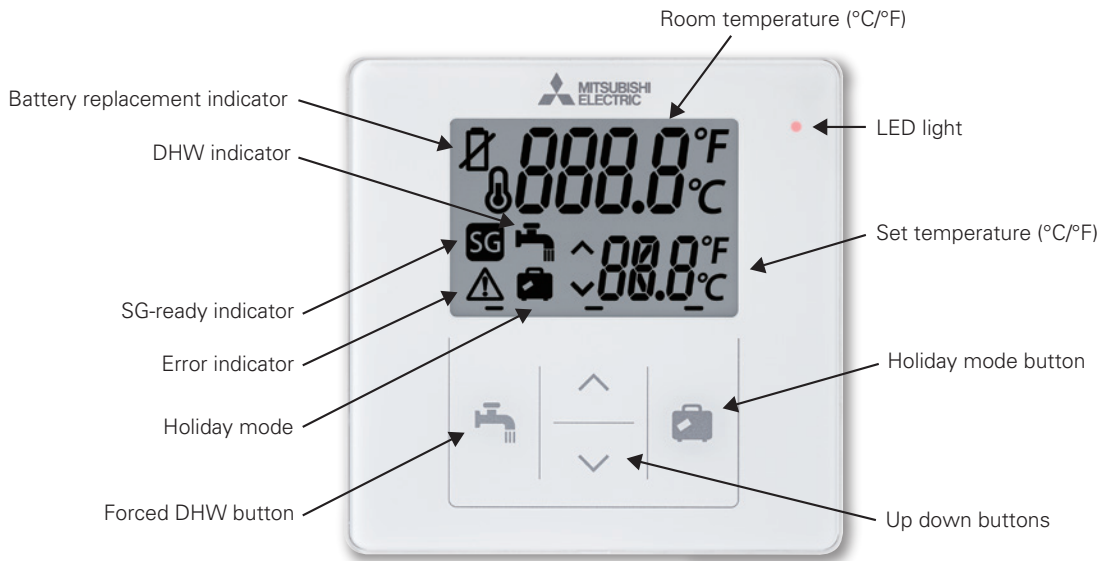

### Flexible Installation

You can choose to mount it on the wall or place it on a stand. The stand design is renewed as well as the functionality.



Wall-mounted\*



Standing

\* The included screws are installed in this image.

### System Error LED Display

A red LED for error indication is added to notify users of abnormal conditions such as backup heater operation or low battery level.



Mode	Flash
Failed*	3 times per 1 minute
Back up heater operation	
Low battery	1 time per 3 minutes

\* When any malfunction occurs in indoor unit, outdoor unit, remote controller or receiver.



# ecodan geodan

## Excellent Performance with Mitsubishi Electric First Residential Ground Source Heat Pump

Ground source heat pump works best especially in replacement from old ground source heat pump.

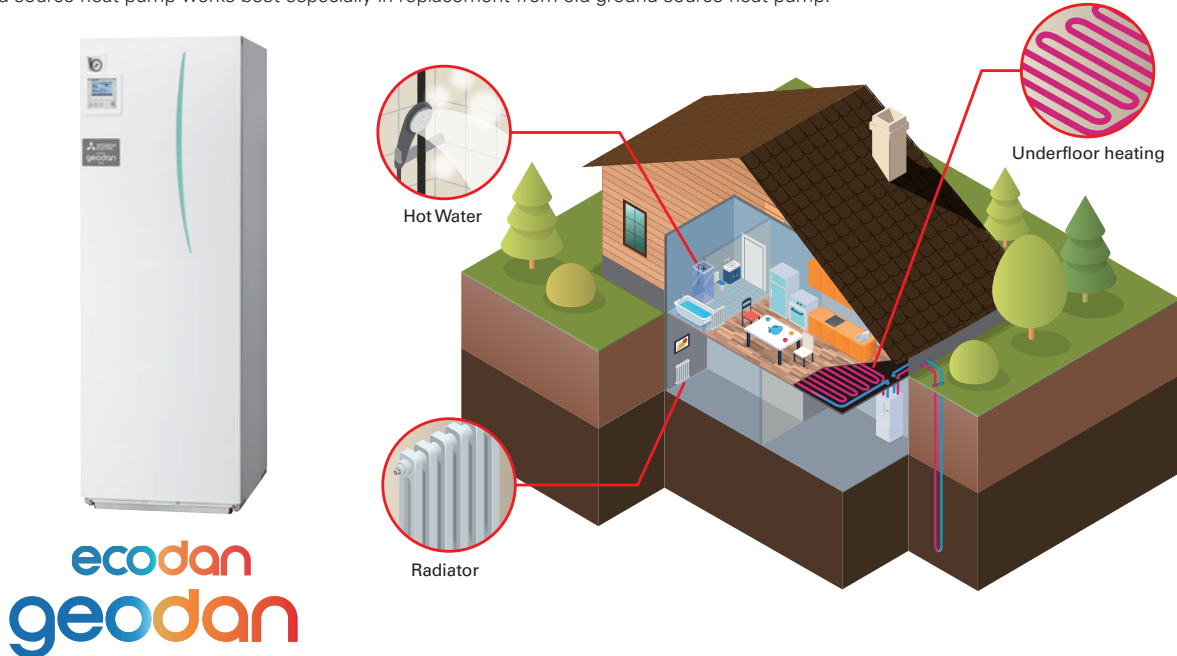

### Performance / Function

#### High Performance

ErP Lot 1 Compliant with highest seasonal space heating energy efficiency class A+++ (A+++ → D).



TIME FOR R32

Low GWP refrigerant R32 contributes the reduction of CO<sub>2</sub> emission compared with conventional R410A refrigerant.

#### A+++ Class Energy Efficiency

(range from A+++ → D)

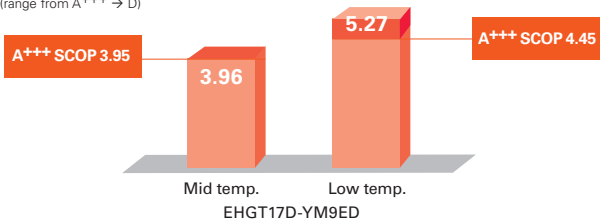

#### <ATW vs GSHP> CO<sub>2</sub> equivalent emission

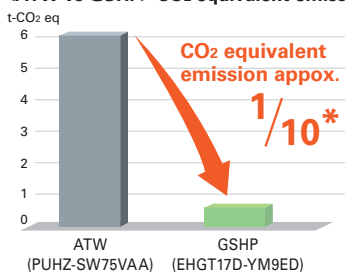

Model name	PUHZ-SW75VAA	EHT17D-YM9ED
Refrigerant amount	3.0kg	0.9kg
GWP	2088 (R410A)	675 (R32)
t-CO <sub>2</sub> eq	6.264	0.608

\* Source: IPCC 4th Assessment Report, global warming potential (GWP) 100-year value. Comparison of 2088(R410A) and 675 (R32).

#### New Compressor Frequency Control

By reducing frequency changes (from 17 to 4 times per hour), hunting is prevented. Reducing fluctuation improves efficiency and prolongs compressor life.

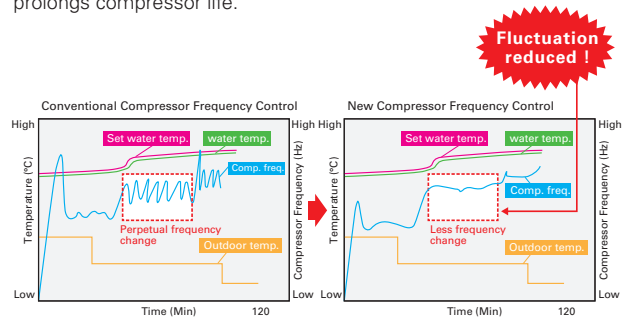

#### Borehole Protection Control

When the unit detects low underground temperature, it automatically reduces the capacity by decreasing heat source collection in order to protect the borehole.

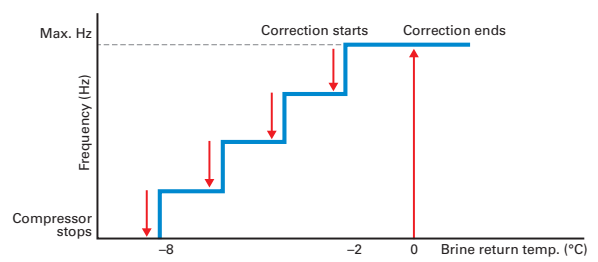

When the brine return temperature is below -8°C and brine outlet temperature is below -12°C, the unit operates only by booster heater. The correction temperature can be changed by dip SW.

## Comfort with Lower Noise

Mitsubishi Electric heat pumps are designed to give you highly efficient and eco-friendly heating with the lowest possible noise level. ecodan geodan achieved industry-leading low noise, 42dB(A)\*.

\*B0W35 Rated condition

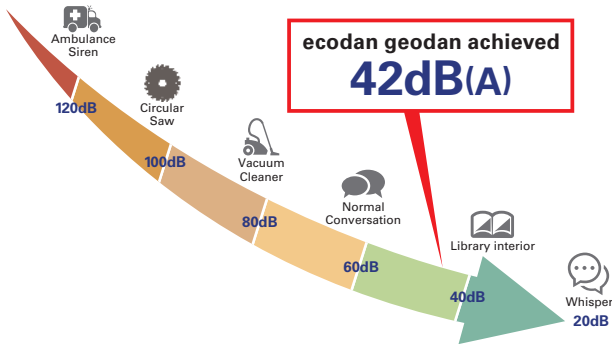

## Silencing Noise

The triple covering structure of the compressor unit greatly reduces sound level through noise absorption.

### 1st Cover

Compressor sound insulation box (with noise absorbing felt and damper)

### 2nd Cover

Module Box (with noise absorbing felt)

### 3rd Cover

Outside panel (with noise absorbing felt)

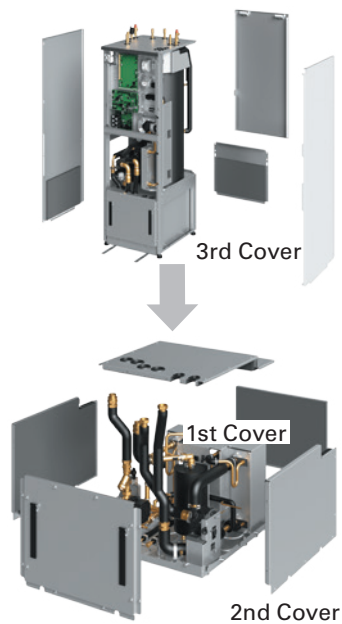

## Avoiding Vibration Noise

Rubber mounted stabilizer plate cushions the vibration noise of the compressor.



## Easy Installation & Transportation

At only 1750mm, ecodan geodan is the class-leading compact unit on the market, making it the ideal solution for rooms and basements with a low ceiling height.

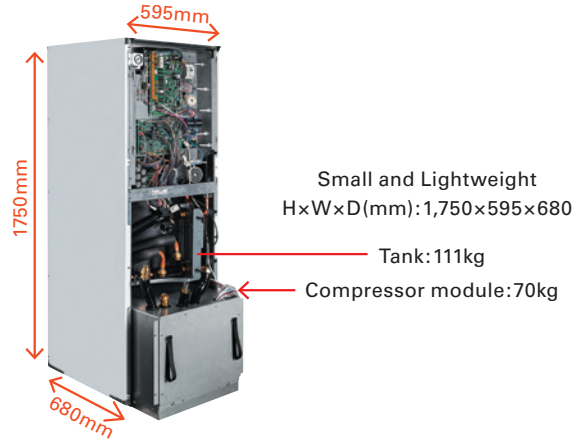

## Easy Transportation

Compressor module can be removed for easier installation and transportation. Once removed, the tank can be transported horizontally.



## Flexible Piping Work

Pipings on top are placed in a Zig-Zag shape. This enables easier installation without interrupting each piping work, especially in case of replacement.



## Easy Adjustment

Adjust bolt capable of 50mm expansion for easy installation even on uneven surfaces.

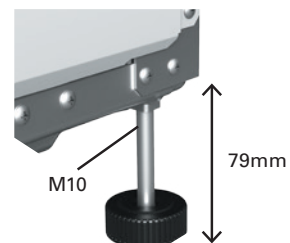

## Ground Source Heat Pump Specifications

Specification with 38% propylene glycol

Model name		EHGT17D-YM9ED	
Heating Capacity (Min-Max)		2.5-10.0kW	
Heat Output B0/W35 (Rated)		5.0kW	
COP B0/W35		4.58	
SCOP (Average Climate)	Low Temp	5.27	
	Rank (A+++ → D)	A+++	
	$\eta_s^{*2}$	203%	
	Mid Temp	3.96	
	Rank (A+++ → D)	A+++	
L Load Profile (Average Climate)* <sup>3</sup>	$\eta_{wh}$	131%	
	Rank (A+ → F)	A+	
Sound Power Level (Rated)* <sup>4</sup>		42dB(A)	
Refrigerant /Amount		R32* <sup>1</sup> /0.9kg	
GWP		608	
Dimensions (HxWxD)		1,750mmx595mmx680mm	
DHW Tank		170L (Net)	
Weight		Unit 181kg	
Electrical data	Heat pump	Power supply	3ph/400V/50Hz
		Max current	8A
		Breaker	16A
	Booster heater	Power supply	3ph/400V/50Hz
		Capacity	3kW+6kW
		Current	13A
		Breaker	16A
Connections	Water	Primary circuit	ø28mm
		DHW circuit	ø22mm
	Brine	Brine circuit	ø28mm
Operating range	Heating	Room temperature	10~30°C
		Flow temperature	20~60°C
	DHW		40~60°C
	Legionella prevention		60~70°C
Guaranteed operating range	Ambient		0~35°C
			≤80%RH
	Water outlet temperature		20~60°C
	Brine inlet temperature		-8~30°C
		Min. brine outlet temperature	-12°C
Flow rate range	Primary circuit	Max.	27.7L/min
		Min.	7.1L/min
	Brine circuit	Max.	27.7L/min
		Min.	7.1L/min
Heat source fluid type		29 WT% Bioethanol	
		38 WT% Propylene glycol	
		25 WT% Ethylene glycol	

\*1 Refrigerant leakage contribute to climate change. Refrigerant with lower global warming potential (GWP) would contribute less to global warming than a refrigerant with higher GWP, if leaked to the atmosphere. This appliance contains a refrigerant fluid with a GWP equal to 550. This means that if 1 kg of this refrigerant fluid would be leaked to the atmosphere, the impact on global warming would be 550 times higher than 1 kg of CO<sub>2</sub>, over a period of 100 years. Never try to interfere with the refrigerant circuit yourself or disassemble the product yourself and always ask a professional. The GWP of R32 is 675 in the IPCC 4th Assessment Report.

\*2  $\eta_s$  values are measured based on EN14825. \*3  $\eta_{wh}$  values are measured based on EN16147. \*4 Sound power levels are measured based on EN12102.

# ecodan MULTI COMFORT



## PXZ SERIES

Air-to-Air and Air-to-Water Hybrid Multi Split System

1 Unit, 2 Roles – Total Comfort Year-round

Air Conditioning and Hot Water Supply Matching Every Home's Needs

All-in-one outdoor unit: air conditioning, domestic hot water supply and hot water heating



### PXZ for summer

PXZ enables cooling of multiple rooms by ATA and supply hot water by ATW.



### PXZ for winter

PXZ enables heating of multiple rooms by ATA and supply hot water by ATW.

## Indoor unit line up

### Air-to-Air Wall-mounted

MSZ-LN



MSZ-EF



MSZ-AY

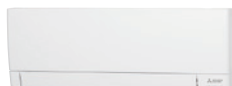

### Floor-standing

MFZ



### Ceiling-concealed

PEAD

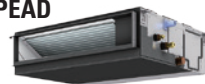

SEZ

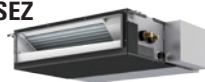

### Ceiling-suspended

PCA



### Air-to-Water Ecodan Hydrobox/Cylinder



Usage Patterns All-in-one System Solution

**Summer 2-in-1 Operation**

Secure total indoor comfort by cooling with ATA and producing DHW by ATW in summer. During the times your ATA is not cooling, your heat pump will produce DHW stored in your tank. Hot summer days will become a breeze with cooling ATA and you can enjoy DHW for all your needs with ATW.

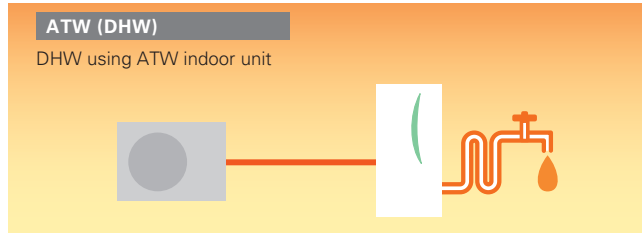
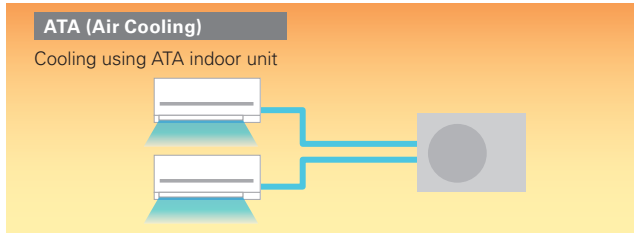

**Spring & Autumn 2-in-1 Operation**

Secure total indoor comfort by heating with ATA and producing DHW by ATW in spring and autumn. During the times your ATA is not heating, your heat pump will produce DHW stored in your tank. ATA will quickly warm up your room even during the chilly morning and evening and you can

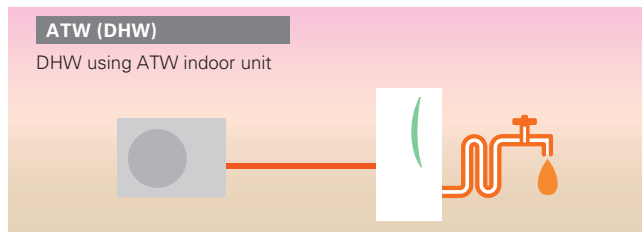
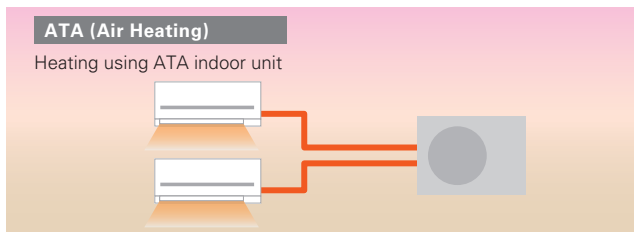

**Winter ecodan**

Secure total indoor comfort by heating and producing DHW by ATW in winter. During the times your ATW is not heating, your heat pump will produce DHW stored in your tank. ATW heating will keep your home warm all the day in severe cold weather and you can enjoy DHW for all your needs with ATW.

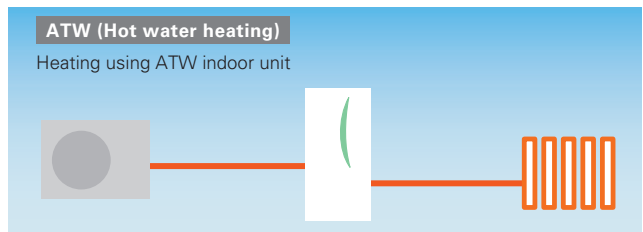
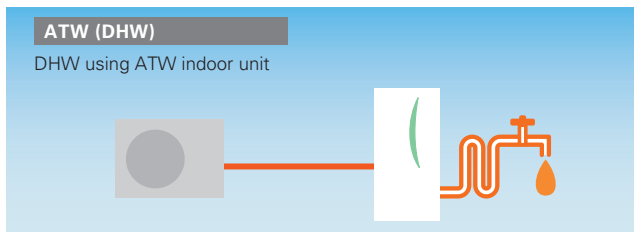

\* If DHW operation starts during ATA operation, ATA operation will temporarily stop. Therefore, it is recommended to set a schedule timer so that DHW operates during the night or when you are not at home.

Outdoor unit line up

Compact design fitting into narrow spaces, ideal for condominiums and villas.

**New system PXZ**

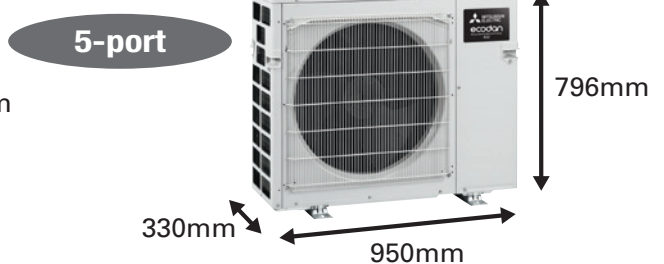
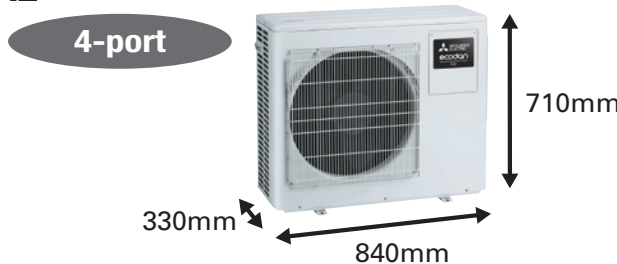

## Quiet mode

Quiet mode allows PXZ to run silently while cooling or heating your home.

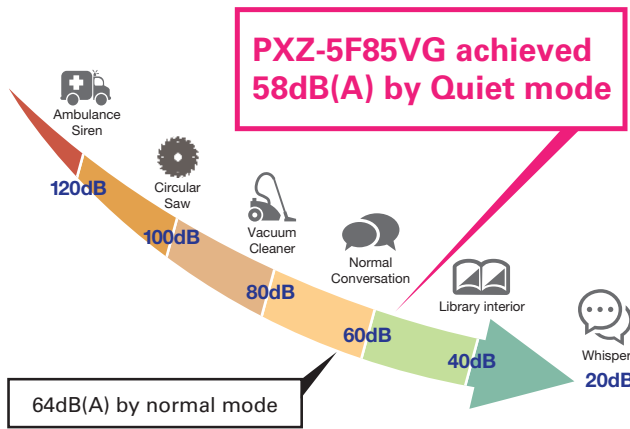

- \* The cooling and heating capacity may drop if this function is activated.
- \* When the outside air temperature is low during heating, the heating capacity is prioritized and the unit may not be quiet. Also, if the outside air temperature is high during cooling, the cooling capacity is prioritized and the unit may not be quiet.
- \* Sound power level values are based on EN12102.
- \* Capacity values are based on EN14511
- \* To activate Quiet mode, changing the setting is required.

## Max 55°C outlet water temp

For the hot water supply with PXZ, a maximum outlet water temperature of 55°C is secured.

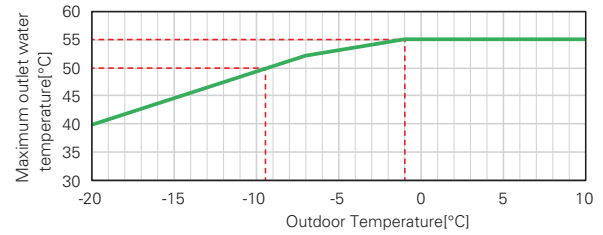

## High Performance Hot Water Supply

ErP Lot 1 Compliant with highest seasonal space heating energy efficiency class A++ (range from A+++ to D).

Low GWP refrigerant R32 contributes the reduction of CO<sub>2</sub> emission compared with conventional R410A refrigerant.

## A+++ Class Energy Efficiency

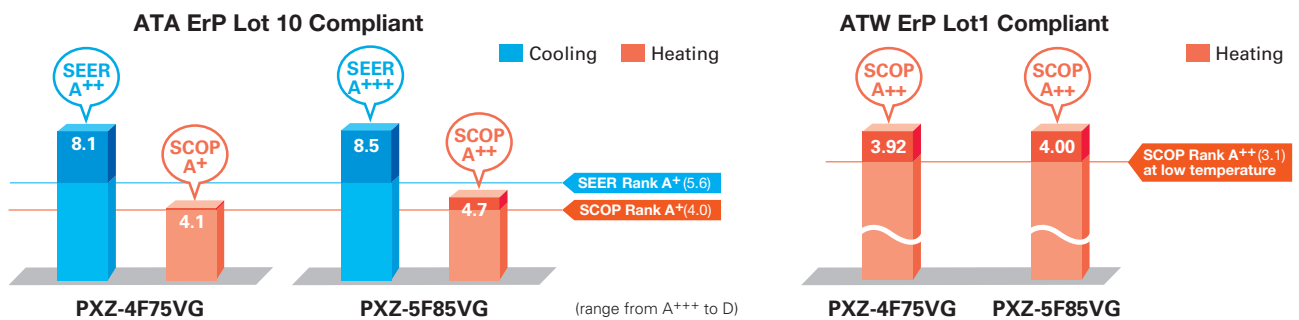

## New System Benefits

End users only need to purchase a single outdoor unit, as PXZ is connectable to both RAC and Ecodan. With house expansions or room redistributions, additional indoor units can be installed in the future.

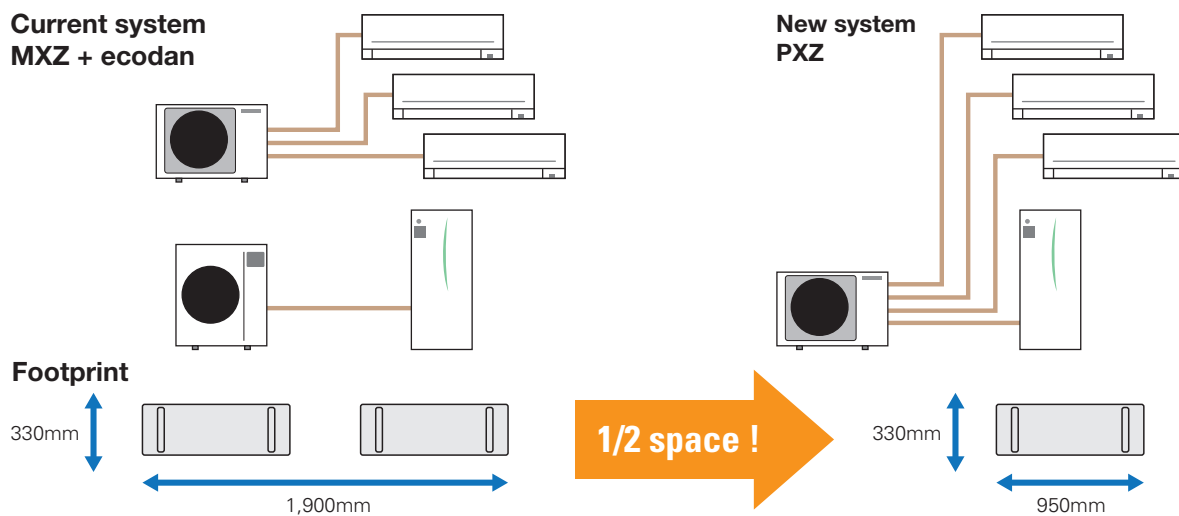

**And more benefits like...**

- Cost saving by reducing the number of systems.
- Additional indoor units up to 4 or 5 ports can be installed.

## Specifications

### PXZ-4F75VG

Maximum Piping Length	
Outdoor unit - Indoor unit (a,b,c,d)	30m
Total length (a+b+c+d)	60m

Maximum Number of Bends	
Outdoor unit - Indoor unit (a,b,c,d)	25
Total number (a+b+c+d)	60

#### Indoor units

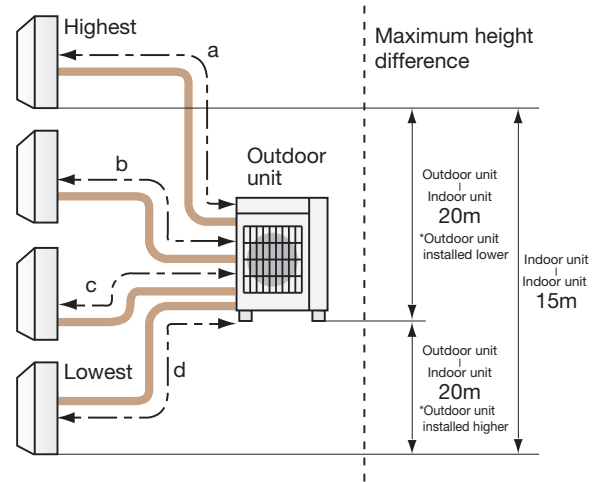

### PXZ-5F85VG

Maximum Piping Length	
Outdoor unit - Indoor unit (a,b,c,d)	30m
Total length (a+b+c+d)	70m

Maximum Number of Bends	
Outdoor unit - Indoor unit (a,b,c,d)	25
Total number (a+b+c+d)	70

#### Indoor units

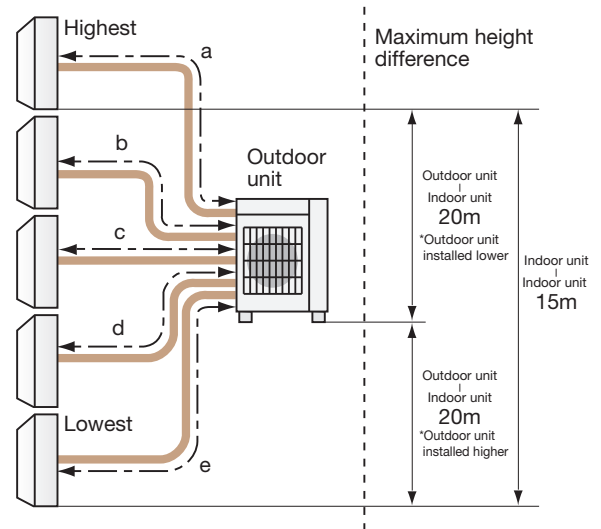

# Specifications

Outdoor Unit				PXZ-4F75VG(2)	PXZ-5F85VG(2)		
Air-to-Air (ATA)	Cooling	Capacity	Rated (35°C)	kW	7.2	8.3	
			Min-Max	kW	3.7-8.8	3.7-9.2	
		Total Input	Rated (35°C)	kW	1.85	1.97	
		EER*1			3.89	4.21	
		Design load		kW	7.2	8.3	
		Annual electricity consumption*2		kWh/a	311	342	
		SEER*1*3			8.1	8.5	
			Energy efficiency class		A++	A+++	
		Heating	Capacity	Rated (7°C)	kW	8.6	9.3
				Rated (-7°C)	kW	6.20	6.20
	Min-Max (7°C)			kW	3.4-10.7	3.4-11.6	
	Total Input		Rated (7°C)	kW	1.87	2.00	
	COP*1				4.60	4.65	
	Design load			kW	7.0	7.0	
	Declared Capacity		at reference design temperature	kW	5.6	5.8	
			at bivalent temperature	kW	6.2	6.2	
			at operation limit temperature	kW	4.8	4.9	
	Back up heating capacity			kW	1.4	1.2	
	Annual electricity consumption*2		kWh/a	2,389	2,087		
	SCOP*1*3			4.1	4.7		
	Energy efficiency class		A+	A++			
Sound Level (SPL)	Cooling		dB(A)	48	49		
	Heating		dB(A)	54	51		
Sound Power Level (PWL)*4	Cooling		dB(A)	63	61		
	Heating		dB(A)	69	63		
Outdoor unit	Supply(V/Phase/Hz)			230V/1phase/50Hz			
	Air Volume	ATA heating	m3/min	42.7	62		
		ATA Cooling	m3/min	35.4	57		
		ATW heating	m3/min	42.7	62		
		ATW DHW (ecodan indoor unit)	m3/min	42.7	62		
	Guaranteed Operating Range	ATA heating	°C	-20°C DB-24°C DB	-20°C DB-24°C DB		
		ATA Cooling	°C	-10°C DB-46°C DB	-10°C DB-46°C DB		
		ATW heating	°C	-20°C DB-24°C DB	-20°C DB-24°C DB		
		ATW DHW (ecodan indoor unit)	°C	-20°C DB-35°C DB	-20°C DB-35°C DB		
	Dimensions	H×W×D	mm	710×840(+30)×330(+66)	796×950×330		
	Weight		kg	59	62		
	Operating Current (max)		A	18	21.4		
Breaker Size		A	25	25			
Ext.Piping	Diameter	Liquid/Gas	mm	6.35x4/12.7x1+9.52x3	6.35x5/12.7x1+9.52x4		
	Each indoor unit piping length (max)		m	30	30		
	Max.Length	Out-In	m	60	70		
	Max.Height	Out-In	m	20	20		
	Chargeless length		m	60	70		
Refrigerant	Amount	Pre-charged	kg	R32*5	R32*5		
		Maximum	kg	2.4	2.4		
			kg	2.4	2.4		
Number of total port	Available indoor unit ATA	Quantity		1~3	1~4		
	Available indoor unit ATW	Quantity		1	1		
ecodan connection (Mitsubishi Electric supplied indoor unit)	Heating	A7W35*6	Capacity nom	kW	7.5	8.5	
			Capacity max	kW	9.3	10.0	
			Total Input nom	kW	1.80	1.96	
			Total Input max	kW	2.61	2.51	
			COP nom		4.17	4.34	
		COP max		3.57	3.99		
		A7W55*6	Capacity	kW	7.50	8.50	
			Total Input	kW	3.05	3.26	
			COP		2.46	2.61	
		A2W35*6	Capacity nom	kW	6.80	7.80	
			Capacity max	kW	6.80	7.80	
			Total Input nom	kW	2.43	2.60	
			Total Input max	kW	2.43	2.60	
			COP nom		2.80	3.00	
		COP max		2.80	3.00		
	SSHE 35°C Average condition	Class		A++	A++		
		ηS*7		154%	157%		
		SCOP		3.92	4.00		
	SSHE 55°C Average condition	Class		A+	A+		
		ηS*7		113%	111%		
		SCOP		2.91	2.86		
	DHW*8 (ecodan indoor unit)	DHW 200L Load Profile	Class	A+	A+		
		Average condition	ηWH*9	130%	135%		
COP DHW			3.13	3.26			
Max outlet water temperture		°C	55	55			
Sound Level (SPL)	Heating		dB(A)	57	54		
	DHW (ecodan indoor unit)		dB(A)	57	54		
Sound Power Level (PWL)*4	Heating		dB(A)	67	64		
	DHW (ecodan indoor unit)		dB(A)	67	64		

\*1 EER/COP, SEER/SCOP values and energy efficiency class are measured when connected to the indoor units listed below.

PXZ-4F75VG → MSZ-LN18VG2 + MSZ-LN18VG2 + MSZ-LN18VG2 + MSZ-LN18VG2

PXZ-5F85VG → MSZ-LN18VG2 + MSZ-LN18VG2 + MSZ-LN25VG2 + MSZ-LN25VG2

\*2 Energy consumption based on standard test results. Actual energy consumption will depend on how the appliance is used and where it is located.

\*3 SEER and SCOP are based on 2009/125/EC:Energy-related Products Directive and Regulation(EU) No206/2012.

\*4 Sound power levels are measured based on EN12102.

\*5 Refrigerant leakage contributes to climate change. Refrigerant with lower global warming potential (GWP) would contribute less to global warming than a refrigerant with higher GWP, if leaked to the atmosphere. This appliance contains a refrigerant fluid with a GWP equal to 675. This means that if 1 kg of this refrigerant fluid would be leaked to the atmosphere, the impact on global warming would be 675 times higher than 1 kg of CO<sub>2</sub>, over a period of 100 years. Never try to interfere with the refrigerant circuit yourself or disassemble the product yourself and always ask a professional. The GWP of R32 is 675 in the IPCC 4th Assessment Report.

\*6 Air-to-Water values are measured based on EN14511 (Circulation pump input is not included).

\*7 ηs values are measured based on EN14825.

\*8 When connecting to E\*\*D-\*\*\*E.

\*9 ηwh values are measured based on EN16147.

## PXZ + Ecodan Compatibility Table

Indoor unit		Outdoor unit	PXZ	
			4F75VG(2)	5F85VG(2)
M series	Wall Mounted	MSZ-RW25VG	○	○
		MSZ-RW35VG	○	○
		MSZ-RW50VG	○	○
		MSZ-LN25VG2	○	○
		MSZ-LN35VG2	○	○
		MSZ-LN50VG2	○	○
		MSZ-EF18VG(K)	○	○
		MSZ-EF22VG(K)	○	○
		MSZ-EF25VG(K)	○	○
		MSZ-EF35VG(K)	○	○
		MSZ-EF42VG(K)	○	○
		MSZ-EF50VG(K)	○	○
		MSZ-AP15VG(K)	○	○
		MSZ-AP20VG(K)	○	○
		MSZ-AP25VG(K)	○	○
		MSZ-AP35VG(K)	○	○
		MSZ-AP42VG(K)	○	○
		MSZ-AP50VG(K)	○	○
		MSZ-AP60VG(K)	○	○
		MSZ-AP71VG(K)	○	○
		MSZ-AY15VGK(P)	○	○
		MSZ-AY20VGK(P)	○	○
		MSZ-AY25VGK(P)	○	○
		MSZ-AY35VGK(P)	○	○
	MSZ-AY42VGK(P)	○	○	
	MSZ-AY50VGK(P)	○	○	
	MSZ-BT20VG(K)	○	○	
	MSZ-BT25VG(K)	○	○	
	MSZ-BT35VG(K)	○	○	
	Floor Standing*1	MFZ-KT25VG	○	○
		MFZ-KT35VG	○	○
		MFZ-KT50VG	○	○
	S series	Ceiling Concealed	SEZ-M25DA(L)	○
SEZ-M35DA(L)			○	○
SEZ-M50DA(L)			○	○
SEZ-M60DA(L)			○	○
SEZ-M71DA(L)			○	○
SEZ-M25DA(L)2			○	○
SEZ-M35DA(L)2			○	○
SEZ-M50DA(L)2			○	○
SEZ-M60DA(L)2			○	○
SEZ-M71DA(L)2			○	○
P series	Ceiling Suspended*2	PCA-M50KA	○	
		PCA-M60KA	○	
		PCA-M50KA2	○	
		PCA-M60KA2	○	
	Ceiling Concealed*2	PEAD-M35JA(L)3		○
		PEAD-M50JA(L)	○	○
		PEAD-M60JA(L)	○	○
		PEAD-M71JA(L)	○	○
		PEAD-M50JA(L)2	○	○
		PEAD-M60JA(L)2	○	○
PEAD-M71JA(L)2	○	○		

\*Total ATA IU HEX volume should NOT exceed a certain level. Please contact us for the further information.

\*1 When connecting to MFZ, MAC-001MF is required to install to suppress noise.

\*2 When connecting to PEAD-M60/71 or PCA-M60/71, it is prohibited to connect other ATA.

## PXZ + ecodan ATW Compatibility Table

Indoor unit		Outdoor unit	PXZ	
			4F75VG(2)	5F85VG(2)
Cylinder		EHST17D-VM2D	○	○
		EHST17D-YM9D	○	○
		EHST20D-VM2D	○	○
		EHST20D-VM6D	○	○
		EHST20D-YM9D	○	○
		EHST20D-YM9ED	○	○
		EHST20D-TM9D	○	○
		EHST30D-VM6ED	○	○
		EHST30D-YM9ED	○	○
		EHST30D-TM9ED	○	○
		ERST17D-VM2D	○	○
		ERST17D-VM6D	○	○
		ERST20D-VM2D	○	○
		ERST20D-VM6D	○	○
		ERST20D-YM9D	○	○
		ERST30D-VM2ED	○	○
		ERST30D-VM6ED	○	○
		ERST30D-YM9ED	○	○
		EHST17D-VM2E	○	○
		EHST17D-YM9E	○	○
		EHST20D-VM2E	○	○
		EHST20D-VM6E	○	○
		EHST20D-YM9E	○	○
		EHST20D-TM9E	○	○
		EHST30D-VM6EE	○	○
		EHST30D-YM9EE	○	○
		EHST30D-TM9EE	○	○
		ERST17D-VM2E	○	○
		ERST17D-VM6E	○	○
		ERST20D-VM2E	○	○
		ERST20D-VM6E	○	○
		ERST20D-YM9E	○	○
		ERST30D-VM2EE	○	○
ERST30D-VM6EE	○	○		
ERST30D-YM9EE	○	○		
Hydrobox		EHSD-VM2D	○	○
		EHSD-VM6D	○	○
		EHSD-YM9D	○	○
		EHSD-YM9ED	○	○
		EHSD-TM9D	○	○
		ERSD-VM2D	○	○
		ERSD-VM6D	○	○
		ERSD-YM9D	○	○
		EHSD-VM2E	○	○
		EHSD-VM6E	○	○
		EHSD-YM9E	○	○
		EHSD-TM9E	○	○
		ERSD-VM2E	○	○
		ERSD-VM6E	○	○
		ERSD-YM9E	○	○

## New Optional Parts Compatibility Table

Parts name	Model name	PXZ	
		4F75VG	5F85VG
Drain hose heater connector	MAC-062RA-E	○	○
Muffler*	MAC-001MF-E	○	○

\*Please connect the muffler to the gas piping within 3 meters from the piping connection port of the outdoor unit.

\*Please attach this if you are concerned about refrigerant noise.

# ecodan MULTI LIGHT PXZ + DHW TANK



## Ecodan Multi Light

Ecodan Multi Light is the ideal solution where air-based comfort is acceptable and high flexibility is required: for second homes, residential complexes, and in climates that are not particularly harsh. The system consists of a multisplit heat pump to which up to four direct-expansion indoor units can be connected to provide heating and cooling, as well as a 200-liter stainless steel hot water storage tank to ensure domestic hot water production.

### Domestic Hot Water Storage Tank Indoor Unit

The new domestic hot water storage tank has a capacity of 200 liters and includes the following components:

- 1.5 kW immersion heater
- Control panel (HMI)
- Dual domestic hot water temperature sensors

### Outdoor unit

The PXZ-5F85VG2 model with an output of 8.50 kW is available and allows the connection of up to 5 indoor units (1 DHW storage tank + 4 direct-expansion air indoor units).

Ecodan Multi heat pumps from the PXZ Series offer a uniquely easy installation, as all direct-expansion air indoor units, selectable from a wide range, can be connected directly to the outdoor unit. This significantly reduces system installation time as well as the masonry work required for system installation.



## Operating modes

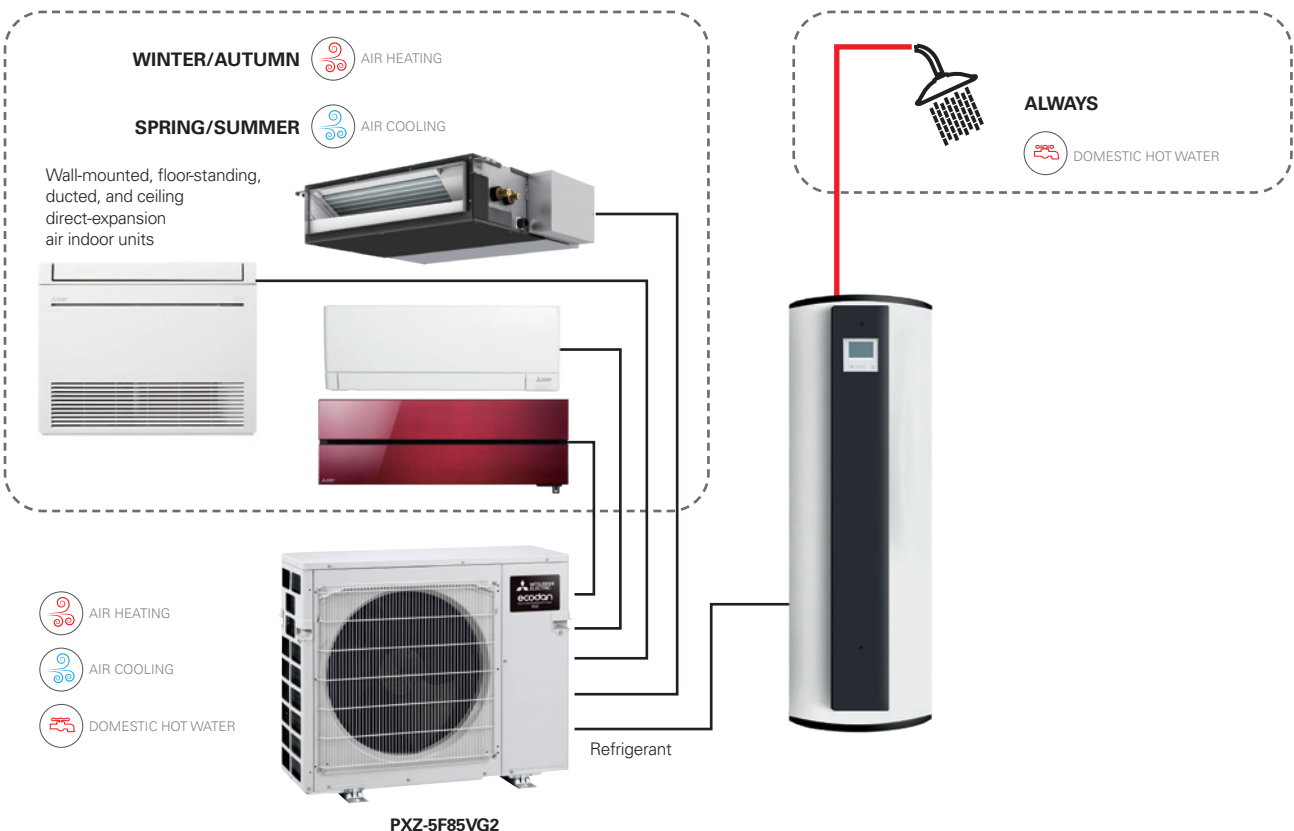

## Specifications

Outdoor Unit				PXZ-5F85VG2		
Air-to-Air (ATA)	Cooling	Capacity	Rated (35°C)	kW	8.3	
			Min-Max	kW	3.7-9.2	
		Total Input	Rated (35°C)	kW	1.97	
		EER*1			4.21	
		Design load		kW	8.3	
		Annual electricity consumption*2		kWh/a	342	
		SEER*1*3			8.5	
			Energy efficiency class		A+++	
		Heating	Capacity	Rated (7°C)	kW	9.3
				Rated (-7°C)	kW	6.20
			Min-Max (7°C)	kW	3.4-11.6	
	Total Input		Rated (7°C)	kW	2.00	
	COP*1				4.65	
	Design load			kW	7.0	
	Declared Capacity		at reference design temperature	kW	5.8	
			at bivalent temperature	kW	6.2	
			at operation limit temperature	kW	4.9	
	Back up heating capacity			kW	1.2	
	Annual electricity consumption*2		kWh/a	2,087		
	SCOP*1*3			4.7		
	Energy efficiency class		A++			
Sound Level (SPL)	Cooling		dB(A)	49		
	Heating		dB(A)	51		
Sound Power Level (PWL)*4	Cooling		dB(A)	61		
	Heating		dB(A)	63		
Outdoor unit	Supply(V/Phase/Hz)			230V/1phase/50Hz		
	Air Volume	ATA heating	m3/min	62		
		ATA Cooling	m3/min	57		
		ATW heating	m3/min	62		
		ATW DHW (ecodan indoor unit)	m3/min	62		
	Guaranteed Operating Range	ATA heating	°C	-20°C DB-24°C DB		
		ATA Cooling	°C	-10°C DB-46°C DB		
		ATW heating	°C	-20°C DB-24°C DB		
		ATW DHW (ecodan indoor unit)	°C	-20°C DB-35°C DB		
	Dimensions	HxWxD	mm	796x950x330		
	Weight		kg	62		
	Operating Current (max)		A	21.4		
	Breaker Size		A	25		
	Ext.Piping	Diameter	Liquid/Gas	mm	6.35x5/12.7x1+9.52x4	
		Each indoor unit piping length (max)		m	30	
Max.Length		Out-In	m	70		
Max.Height		Out-In	m	20		
Chargeless length			m	70		
Refrigerant	Amount	Pre-charged	kg	2.4		
		Maximum	kg	2.4		
				R32*5		
Number of total port	Available indoor unit ATA	Quantity		1~4		
	Available indoor unit ATW	Quantity		1		

\*1 EER/COP, SEER/SCOP values and energy efficiency class are measured when connected to the indoor units listed below.

PXZ-4F75VG → MSZ-LN18VG2 + MSZ-LN18VG2 + MSZ-LN18VG2 + MSZ-LN18VG2

PXZ-5F85VG → MSZ-LN18VG2 + MSZ-LN18VG2 + MSZ-LN25VG2 + MSZ-LN25VG2

\*2 Energy consumption based on standard test results. Actual energy consumption will depend on how the appliance is used and where it is located.

\*3 SEER and SCOP are based on 2009/125/EC:Energy-related Products Directive and Regulation(EU) No206/2012.

\*4 Sound power levels are measured based on EN12102.

\*5 Refrigerant leakage contributes to climate change. Refrigerant with lower global warming potential (GWP) would contribute less to global warming than a refrigerant with higher GWP, if leaked to the atmosphere. This appliance contains a refrigerant fluid with a GWP equal to 675. This means that if 1 kg of this refrigerant fluid would be leaked to the atmosphere, the impact on global warming would be 675 times higher than 1 kg of CO<sub>2</sub>, over a period of 100 years. Never try to interfere with the refrigerant circuit yourself or disassemble the product yourself and always ask a professional. The GWP of R32 is 675 in the IPCC 4th Assessment Report.



## Technical Specifications for Heating/Cooling/Sanitary Use

MODEL			EST-20-V1
Power supply	Volt./Freq./Ph	V/Hz/n°	230/50/1
General	Version		DHW tank
	Dimensions	HxWxD mm	1570 x 550 x 630
	Weight (empty)	kg	56
	Color	RAL	9010
Operating Range	Ambient temperature	°C	+10 °C / +30°C
DHW Production <sup>1</sup>	RANK (DHW load profile)	A+ →F	A+ (L)
	η <sub>wh</sub>	%	131
	Mixed water at 40°C (V40)	litres	259
DHW Tank	Volume	litres	200
	Material		Stainless Steel
	Immersion heater	kW	1,5
	Maximum current	A	6,5 (Immersion Heater) + 0,3 (PCB)
	Maximum water temperature (outdoor unit only)	°C	55
	Maximum water temperature (outdoor unit + IH)	°C	65
Connections	Refrigerant type		R32
	Refrigerant (liquid/gas)	mm (in)	6,35 (1/4) / 9,52 (3/8)
	Water (DHW)	inch	G3/4 F

<sup>1</sup>Based on EN16147



## PXZ + DHW tank Compatibility Table

Indoor unit		Outdoor unit	PXZ
			5F85VG2
M series	Wall Mounted	MSZ-RW25VG	○
		MSZ-RW35VG	○
		MSZ-RW50VG	○
		MSZ-LN25VG2	○
		MSZ-LN35VG2	○
		MSZ-LN50VG2	○
		MSZ-EF18VG(K)	○
		MSZ-EF22VG(K)	○
		MSZ-EF25VG(K)	○
		MSZ-EF35VG(K)	○
		MSZ-EF42VG(K)	○
		MSZ-EF50VG(K)	○
		MSZ-AP15VG(K)	○
		MSZ-AP20VG(K)	○
		MSZ-AP25VG(K)	○
		MSZ-AP35VG(K)	○
		MSZ-AP42VG(K)	○
		MSZ-AP50VG(K)	○
		MSZ-AP60VG(K)	○
		MSZ-AP71VG(K)	○
		MSZ-AY15VGK(P)	○
		MSZ-AY20VGK(P)	○
		MSZ-AY25VGK(P)	○
		MSZ-AY35VGK(P)	○
		MSZ-AY42VGK(P)	○
		MSZ-AY50VGK(P)	○
		MSZ-BT20VG(K)	○
	MSZ-BT25VG(K)	○	
	MSZ-BT35VG(K)	○	
	Floor Standing*1	MFZ-KT25VG	○
		MFZ-KT35VG	○
		MFZ-KT50VG	○
	S series	Ceiling Concealed	SEZ-M25DA(L)
SEZ-M35DA(L)			○
SEZ-M50DA(L)			○
SEZ-M60DA(L)			○
SEZ-M71DA(L)			○
SEZ-M25DA(L)2			○
SEZ-M35DA(L)2			○
SEZ-M50DA(L)2			○
SEZ-M60DA(L)2			○
SEZ-M71DA(L)2	○		
P series	Ceiling Suspended*2	PCA-M50KA	
		PCA-M60KA	
		PCA-M50KA2	
		PCA-M60KA2	
	Ceiling Concealed*2	PEAD-M35JA(L)3	○
		PEAD-M50JA(L)	○
		PEAD-M60JA(L)	○
		PEAD-M71JA(L)	○
		PEAD-M50JA(L)2	○
		PEAD-M60JA(L)2	○
PEAD-M71JA(L)2	○		

\*Total ATA IU HEX volume should NOT exceed a certain level. Please contact us for the further information.

\*1 When connecting to MFZ, MAC-001MF is required to install to suppress noise.

\*2 When connecting to PEAD-M60/71 or PCA-M60/71, it is prohibited to connect other ATA.

## PXZ + DHW tank Compatibility Table

Indoor unit		Outdoor unit	PXZ
			5F85VG2
DHW Tank	EST-20-V1		○

# ecodan CITY MULTI PUMY + ECODAN



Air-to-Air and Air-to-Water Hybrid Multi Split System

1 Unit, 2 Roles – Total Comfort Year-round

Air Conditioning and Hot Water Supply Matching the Needs of Each Room

All-in-one outdoor unit (air conditioning, domestic hot water supply and hot water heating)

**PUMY for Air-to-Air**

PUMY utilises various indoor units, enabling the air conditioning or heating of multiple rooms, and controls each unit individually.

**ecodan for Air-to-Water**

- ✓ Domestic hot water (DHW) supply
- ✓ Heating for multiple rooms

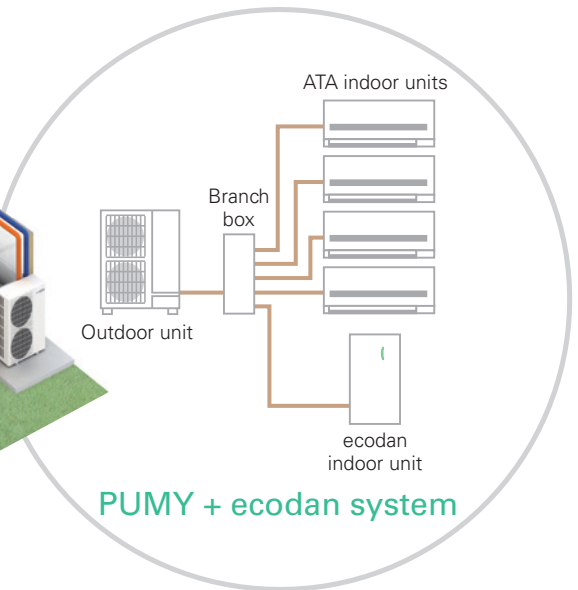

## Main Operation Patterns

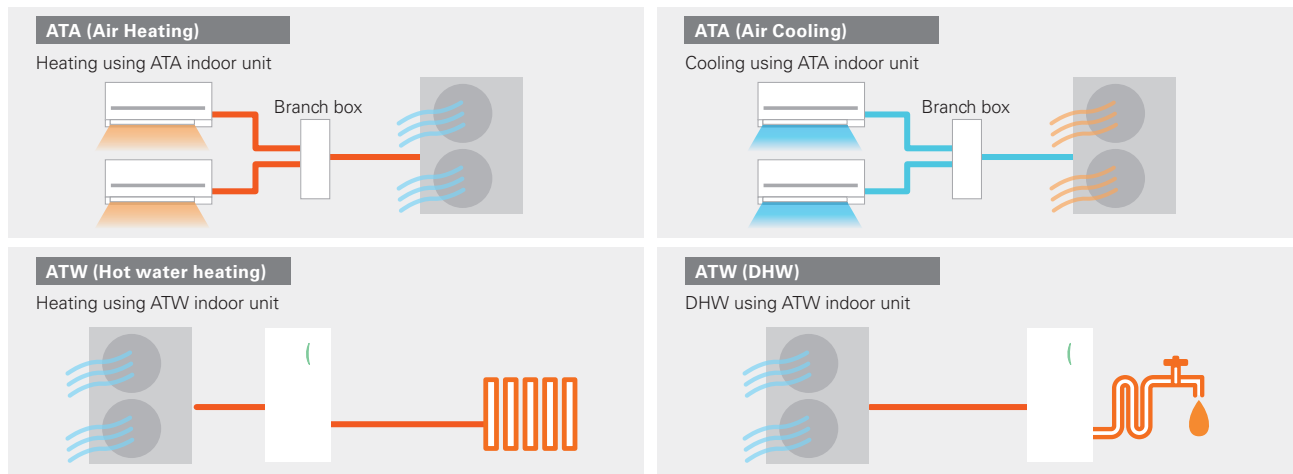

## Optional Operation Patterns\* (simultaneous)

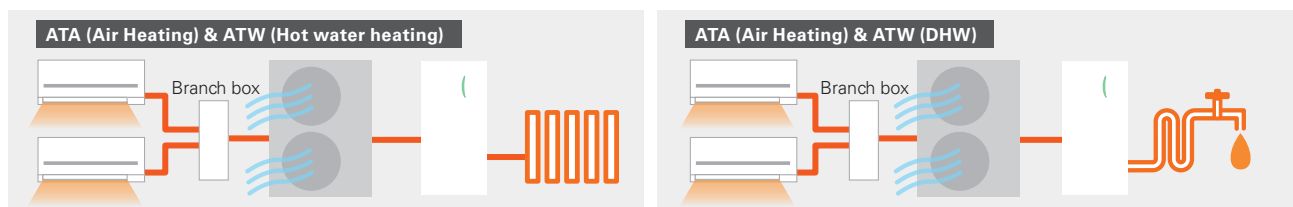

\*When using optional simultaneous operation, there are some restrictions, such as connectable indoor units, operation range and DHW flow temp.

## Usage Pattern All-in-one System Solution

### Summer 2-in-1 Operation

In summer ATA cooling and DHW are utilised. Keep your room comfortable with ATA cooling during high temperature daytime. Heat pump operates to heat up water stored in the DHW tank when ATA is not operated. The hot water can be utilised for shower and washing dishes during daytime.

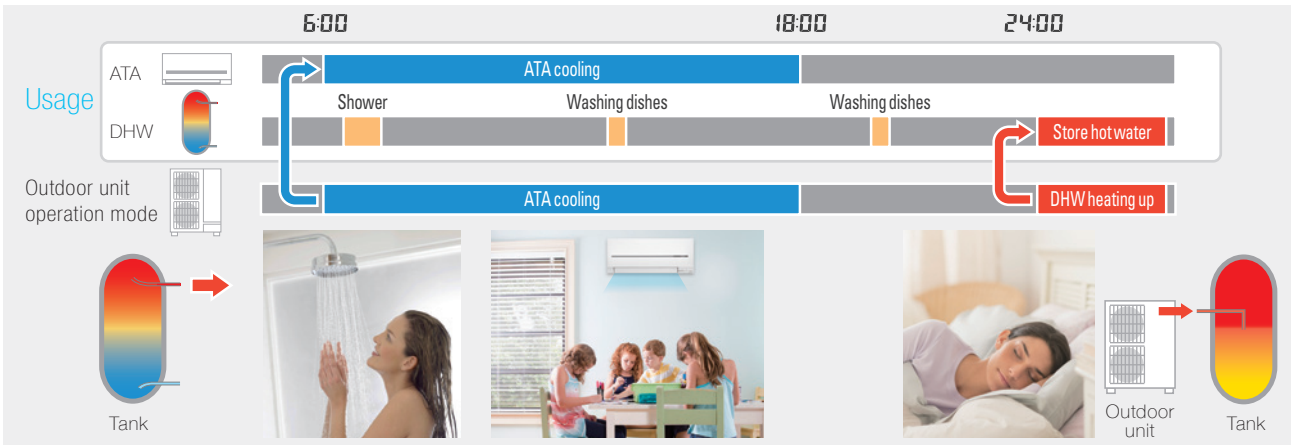

### Spring & Autumn 2-in-1 Operation

In spring and autumn, ATA heating and DHW are utilised. ATA heating can warm up each room quickly during the low temperature morning and evening. Heat pump operates to heat up water stored in the DHW tank when ATA is not operated. The hot water can be utilised for shower and washing dishes during daytime.



### Winter ecodan

In winter ATW heating and DHW are utilised. ATW heating warms home all the day in severe cold weather. ATW heating stops temporarily only when the heat pump operates to heat up water stored in the DHW tank.



# PUMY+ ecodan

Model name				PUMY-P112VKM6(-BS)	PUMY-P125VKM6(-BS)	PUMY-P140VKM6(-BS)	PUMY-P112YKM5(-BS)	PUMY-P125YKM5(-BS)	PUMY-P140YKM5(-BS)	
Power supply				1-phase 220 - 230 - 240V, 50Hz			3-phase 380 - 400 - 415V, 50Hz			
Air-to-Air (ATA)	Cooling (nominal)*1	Capacity	kW	12.5	14.0	15.5	12.5	14.0	15.5	
		Power input	kW	4.34	5.00	5.17	4.34	5.00	5.17	
		EER		2.88	2.80	3.00	2.88	2.80	3.00	
	Temp. range of cooling	Indoor temp.	W.B.	15 - 24°C						
		Outdoor temp.*2	D.B.	-5 - 52°C						
	Heating (nominal)*1	Capacity	kW	14.0	16.0	18.0	14.0	16.0	18.0	
Power input			kW	3.49	4.06	4.63	3.49	4.06	4.63	
COP				4.01	3.94	3.89	4.01	3.94	3.89	
Temp. range of heating		Indoor temp.	W.B.	15 - 27°C						
	Outdoor temp.	D.B.	-20 - 15°C							
Air-to-Water (ATW)	Nominal flow rate (for heating)			L/min						
	Heating*3	A7W35	Capacity	kW	12.5					
			Power input	kW	3.06					
			COP		4.08					
		A2W35	Capacity	kW	10.0					
			Power input	kW	3.50					
			COP		2.86					
	Guaranteed operating range	ATA	Heating	D.B.	-20 - +21°C					
			DHW	D.B.	-20 - +35°C					
			ATA heating + DHW	D.B.	7 - +21°C					
	ATA + ATW	ATA heating + ATW heating *4	Heating	D.B.	-10 - +21°C					
			DHW	D.B.	-10 - +21°C					
ATA heating + ATW heating *4			D.B.	-10 - +21°C						
Maximum Outlet water temp.			°C	55						
Outdoor unit	Indoor unit connectable	ATA only	Total capacity							
			50 to 130% of outdoor unit capacity							
		ATA + ATW individual operation	Model/Quantity	Branch box system	15-100/8	15-100/8	15-100/8	15-100/8	15-100/8	15-100/8
				Mixed system*12	15-140*5/10	15-140*5/10*6	15-140*5/10*6	15-140*5/10	15-140*5/10*6	15-140*5/10*6
		ATA + ATW simultaneous operation	Model/Quantity	Branch box system	15-100/8	15-100/8	15-100/8	15-100/8	15-100/8	15-100/8
				Mixed system*12	15-140*5/10	15-140*5/10*6	15-140*5/10*6	15-140*5/10	15-140*5/10*6	15-140*5/10*6
	Total capacity			ATA : Max 130% of outdoor unit capacity + ATW (EHST20C or EHSC) *7						
	Model/Quantity			Max 100% of outdoor unit capacity : ATA + ATW (EHST20C or EHSC) *7						
	ATA*12			15/1*8	15-25/2*9	15-42*11/3*10	15/1*8	15-25/2*9	15-42*11/3*10	
	ATW			ATW (EHST20C or EHSC) / 1						
	Sound pressure level (measured in anechoic room)			dB<A>	49 / 51	50 / 52	51 / 53	49 / 51	50 / 52	51 / 53
	Sound power level (measured in anechoic room)			dB<A>	69 / 71	70 / 72	71 / 73	69 / 71	70 / 72	71 / 73
Refrigerant piping diameter			Liquid pipe	9.52 flare						
			Gas pipe	15.88 flare						
Fan	Type x Quantity		Propeller fan x 2							
	Airflow rate	m³/min	110							
		L/s	1,883							
		cfm	3,884							
Motor output		kW	0.074 + 0.074							
Compressor	Type x Quantity		Scroll hermetic compressor x 1							
	Starting method		Inverter							
	Motor output		kW	2.9	3.5	3.9	2.9	3.5	3.9	
External dimensions (H x W x D)			mm	1,338 x 1,050 x 330 (+40)						
Weight			kg	122			YKM: 125 / YKME: 136			

\*1

	Indoor	Outdoor	Piping length	Level difference
Cooling	27°C DB / 19°C WB	35°C DB	7.5m	0m
Heating	20°C DB	7°C DB / 6°C WB	7.5m	0m

\*2 10 to 52°C D.B.: When connecting PKFY-P15/20/25VBM, PFFY-P20/25/32VKM, PFFY-P20/25/32VLE(R)M, PEFY-P+VMA3 or M, S and P series indoor unit.

\*3 In the case of ATW single connection. Input to circulation pump is not included.

\*4 In the case of simultaneous operation of ATA heating and ATW heating, target flow temperature range is restricted to 45-55°C and when the ambient temp is under 7°C, the flow temp is lowered.

\*5 Up to P100 when connecting via branch box.

\*6 Up to 11 units when connecting via 2 branch boxes.

\*7 Only one ecodan unit can be connected.

\*8 Exceptionally, one MSZ-SF15VA or MSZ-AP15VF can be connected.

\*9 Exceptionally, two MSZ-SF15VA or MSZ-AP15VF can be connected.

\*10 Exceptionally, three MSZ-SF15VA or MSZ-AP15VF can be connected.

\*11 In the case of City Multi connection, maximum is P32.

\*12 PKFY and PFFY series are not connectable.

## Piping specifications

Item	Unit	Value	Formula
Total piping length	m	150*	a+b+c+d+e+f
Farthest piping length	m	80	a+b+d or a+c+e
		85	a+f
Total piping length between outdoor unit and branch box	m	55	a+b+c
Total piping length between branch boxes and indoor units	m	95	d+e
Farthest piping length from the first joint	m	30	b or c or f
Farthest piping length after branch box	m	25	d or e
Height difference (Outdoor upside / Outdoor downside)	m	50 / 40	

\*When an ecodan is connected, the maximum piping length is 150m.

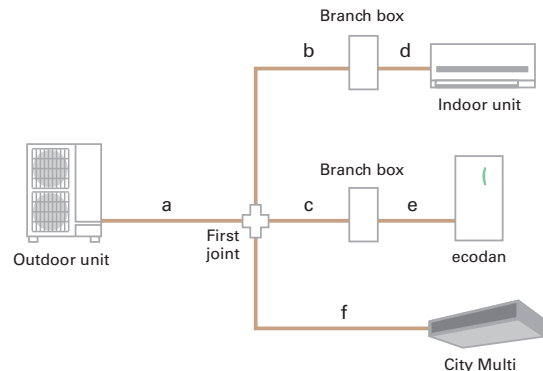

## PUMY+ ecodan Compatibility Table

ATW branch box connection compatibility table

Series	Type	Model name	Compatibility	Type	Model name	Compatibility	Type	Model name	Compatibility
ATW	Cylinder unit	EHST20C-VM2/6D	●	Hydrobox	EHSC-VM2/6D	●	Branch box	PAC-MK54BC	●
		EHST20C-YM9D	●		EHSC-YM9D	●		PAC-MK34BC	●
		ERST20C-VM2E	●		ERSC-VM2E	●			
		ERSC-YM9E	●						

### Connectable indoor unit capacity

For individual operation ATW+ATA (no simultaneous operation) ATW (EHST20C or EHSC) + ATA: Max 130% of outdoor unit capacity

Outdoor capacity 12.5kW	
ATW indoor unit (Cylinder or Hydrobox) 11.2kW	Connectable ATA indoor unit total capacity: Max.16.2kW (130%)
Outdoor capacity 14.0kW	
ATW indoor unit (Cylinder or Hydrobox) 11.2kW	Connectable ATA indoor unit total capacity: Max.18.2kW (130%)
Outdoor capacity 15.5kW	
ATW indoor unit (Cylinder or Hydrobox) 11.2kW	Connectable ATA indoor unit total capacity: Max.20.2kW (130%)

For simultaneous operation of ATW+ATA ATW (EHST20C or EHSC) + ATA: Max 100% of outdoor unit capacity

Outdoor capacity 12.5kW		
ATW indoor unit (Cylinder or Hydrobox) 11.2kW	ATA capacity Max. 1.3kW	*Exceptionally, one MSZ-SF15VA or MSZ-AP15VF can be connected.
Outdoor capacity 14.0kW		
ATW indoor unit (Cylinder or Hydrobox) 11.2kW	ATA capacity Max. 2.8kW	*Exceptionally, two units of MSZ-SF15VA or MSZ-AP15VF can be connected.
Outdoor capacity 15.5kW		
ATW indoor unit (Cylinder or Hydrobox) 11.2kW	ATA capacity Max. 4.3kW	*Exceptionally, three units of MSZ-SF15VA or MSZ-AP15VF can be connected.

# Split Model Specification

## Indoor unit E Generation for PUZ-S(H)WM, SUZ, PXZ, PUHZ, and PUMY-P

### <Cylinder unit (Reversible)>

Model name			ERST17D-VM2E	ERST20D-VM2E	ERST20D-YM9E	ERST30D-VM2EE	ERST30D-YM9EE	
	Type		Heating and cooling					
	Expansion vessel		✓	✓	✓	—	—	
	Booster heater		✓	✓	✓	✓	✓	
Dimensions	H×W×D	mm	1400 × 595 × 680	1600 × 595 × 680		2050 × 595 × 680		
Weight (empty)		kg	91	94	96	108	110	
Control board power supply (Phase / V / Hz)			~N, 230 V, 50 Hz					
Heater	Booster heater	Power supply (Phase / V / Hz)	~N, 230 V, 50 Hz	~N, 230 V, 50 Hz	3~, 400 V, 50 Hz	~N, 230 V, 50 Hz	3~, 400 V, 50 Hz	
		Capacity	kW	2	2	3+6	2	3+6
		Current	A	9	9	13	9	13
		Breaker	A	16	16	16	16	16
Domestic hot water tank	Volume	L	170	200		300		
Guaranteed operating range *1	Indoor unit ambient	°C	0~35°C(≤80 %RH)					
	Outdoor	Heating	°C	See outdoor unit spec table.				
		Cooling	°C	See outdoor unit spec table.*2				
Target temperature range	Heating	Room temperature	°C					10~30
		Flow temperature *4	°C					20~60
	Cooling	Room temperature	°C					—
		Flow temperature	°C					5~25
DHW tank performance	Max. hot water temperature	°C	70					
	Water heating energy efficiency class		Depending on outdoor unit.					
Sound power level (PWL)			dB(A)		41			

### <Cylinder unit (Reversible)>

Model name			ERST20C-VM2E	ERST20F-VM2E	ERST20F-YM9E	ERST30F-VM2EE	ERST30F-YM9EE	
	Type		Heating and cooling					
	Expansion vessel		✓	✓	✓	—	—	
	Booster heater		✓	✓	✓	✓	✓	
Dimensions	H×W×D	mm	1600 × 595 × 680	1600 × 595 × 680		2050 × 595 × 680		
Weight (empty)		kg	99	94	98	109	112	
Control board power supply (Phase / V / Hz)			~N, 230 V, 50 Hz					
Heater	Booster heater	Power supply (Phase / V / Hz)	~N, 230 V, 50 Hz	~N, 230 V, 50 Hz	3~, 400 V, 50 Hz	~N, 230 V, 50 Hz	3~, 400 V, 50 Hz	
		Capacity	kW	2	2	3+6	2	3+6
		Current	A	9	9	13	9	13
		Breaker	A	16	16	16	16	16
Domestic hot water tank	Volume	L	200	200		300		
Guaranteed operating range *1	Indoor unit ambient	°C	0~35°C(≤80 %RH)					
	Outdoor	Heating	°C	See outdoor unit spec table.				
		Cooling	°C	See outdoor unit spec table.*2				
Target temperature range	Heating	Room temperature	°C					10~30
		Flow temperature *4	°C					20~60
	Cooling	Room temperature	°C					—
		Flow temperature	°C					5~25
DHW tank performance	Max. hot water temperature	°C	70					
	Water heating energy efficiency class		Depending on outdoor unit.					
Sound power level (PWL)			dB(A)		41			

\*1 The environment must be frost-free.

\*2 During cooling operation at low outdoor temperature (10°C or lower), frozen water may cause damage on plate heat exchanger.

\*3 For the model without booster heater and immersion heater, the maximum allowable hot water temperature is 3°C lower than maximum outlet water of outdoor unit. For the maximum outlet water of outdoor unit, refer to outdoor unit data book.

\*4 Max temperature is depending on the connected outdoor unit.

# Split Model Specification

## <Hydrobox Reversible>

Model name			ERSD-VM2E	ERSD-YM9E	ERSC-VM2E	ERSC-YM9E	ERSF-VM2E	ERSF-YM9E	ERSE-MEE	ERSE-YM9EE		
Type	Type		Heating and cooling									
	Expansion vessel		✓	✓	✓	✓	✓	✓	—	—		
	Booster heater		✓	✓	✓	✓	✓	✓	—	✓		
Dimensions		H×W×D	mm 800 × 530 × 360									
Weight (empty)		kg	37	39	43	46	39	41	61	63		
Control board power supply (Phase / V / Hz)			~N, 230, 50 Hz				~N, 230, 50 Hz					
Heater	Booster heater	Power supply (Phase / V / Hz)		3~, 230, 50 Hz	3~, 400, 50 Hz	~N, 230, 50 Hz	3~, 400, 50 Hz	~N, 230, 50 Hz	3~, 400, 50 Hz	—	3~, 400, 50 Hz	
		Capacity		kW	2	3+6	2	3+6	2	3+6	—	3+6
		Current		A	9	13	9	13	9	13	—	13
		Breaker		A	16	16	16	16	16	16	—	16
Guaranteed operating range *1	Indoor unit ambient		°C 0~35°C(≤80 %RH)									
	Out-door	Heating		°C See outdoor unit spec table.						10~46		
		Cooling		°C See outdoor unit spec table.*2						10~46		
Target temperature range	Heating	Room temperature		°C 10~30				—				
		Flow temperature *3		°C 20~60				°C 20~70		°C 20~60		
	Cooling	Room temperature		°C —								
		Flow temperature		°C 5~25								
Sound power level (PWL)		dB(A)	41		40		41		45			

\*1 The environment must be frost-free.

\*2 During cooling operation at low outdoor temperature (10°C or lower), frozen water may cause damage on plate heat exchanger.

\*3 Max temperature is depending on the connected outdoor unit.

# E-generation

## Packaged Model Specification

### Indoor unit E Generation for PUZ-WM and PUZ-WZ

#### <Cylinder unit Reversible>

Model name			ERPT17X-VM2E	ERPT20X-VM2E	ERPT20X-VM9E	ERPT30X-VM2EE	ERPT30X-VM9EE			
	Type		Heating and cooling							
	Expansion vessel		✓	✓	✓	—	—			
	Booster heater		✓	✓	✓	✓	✓			
	Immersion heater		—	—	—	—	—			
Dimensions			HxWxD	mm	1400 x 595 x 680	1600 x 595 x 680	1600 x 595 x 680	2050 x 595 x 680	2050 x 595 x 680	
Weight (empty)					kg	84	88	90	104	106
Control board power supply (Phase / V / Hz)			~N, 230 V, 50 Hz							
Heater	Booster heater	Power supply (Phase / V / Hz)		~N, 230 V, 50 Hz	~N, 230 V, 50 Hz	3~, 400 V, 50 Hz	~N, 230 V, 50 Hz	3~, 400 V, 50 Hz		
		Capacity	kW	2	2	3+6	2	3+6		
		Current	A	9	9	13	9	13		
	Breaker		A	16	16	16	16	16		
	Immersion heater *1	Power supply (Phase / V / Hz)		—	—	—	—	—		
		Capacity	kW	—	—	—	—	—		
Current		A	—	—	—	—	—			
Breaker		A	—	—	—	—	—			
Domestic hot water tank	Volume		L	170	200	200	300	300		
Guaranteed operating range *2	Indoor unit ambient		°C	0-35 (≤80%RH)						
	Outdoor	Heating	°C	See outdoor unit spec table.						
		Cooling	°C	See outdoor unit spec table.*3						
Target temperature range	Heating	Room temperature	°C	10-30						
		Flow temperature *4	°C	20-75						
	Cooling	Room temperature	°C	—						
		Flow temperature	°C	5-25						
DHW tank performance	Max. hot water temperature		°C	70						
Water heating energy efficiency class			Depending on outdoor unit.							
Sound power level (PWL)			dB(A)	40						

\*1 Do not fit immersion heaters without thermal cut-out. Use only Mitsubishi Electric service parts as a direct replacement.

\*2 The environment must be frost-free.

\*3 During cooling operation at low outdoor temperature (10°C or lower), frozen water may cause damage on plate heat exchanger.

\*4 Max temperature is depending on the connected outdoor unit.

#### <Hydrobox (Reversible)>

Model name			ERPX-VM2E	ERPX-VM9E		
	Type		Heating and cooling			
	Expansion vessel		✓	✓		
	Booster heater		✓	✓		
	Immersion heater		—	—		
Dimensions			HxWxD	mm	800 x 530 x 360	800 x 530 x 360
Weight (empty)			kg		31	33
Control board power supply (Phase / V / Hz)			~N, 230, 50 Hz		~N, 230, 50 Hz	~N, 230, 50 Hz
Heater	Booster heater	Power supply (Phase / V / Hz)		~N, 230, 50 Hz	3~, 400, 50 Hz	
		Capacity	kW	2	3+6	
		Current	A	9	13	
	Breaker		A	16	16	
Guaranteed operating range *1	Indoor unit ambient		°C	0-35°C (≤80%RH)		
	Outdoor	Heating	°C	See outdoor unit spec table.		
		Cooling	°C	See outdoor unit spec table.*2		
Target temperature range	Heating	Room temperature	°C	10-30		
		Flow temperature *3	°C	20-75		
	Cooling	Room temperature	°C	—		
		Flow temperature	°C	5-25		
Sound power level (PWL)			dB(A)	40		

\*1 The environment must be frost-free.

\*2 During cooling operation at low outdoor temperature (10°C or lower), frozen water may cause damage on plate heat exchanger.

\*3 Max temperature is depending on the connected outdoor unit.



# Packaged Type Specifications

**R32**

## PUZ-(H)WM+E-generation

Model name				PUZ-WM50VHA	PUZ-WM85VAA	PUZ-WM112V/YAA	PUZ-HWM140V/YHA
Refrigerant				R32*1			
Dimensions		HxWxD	mm	943x950x330	1020x1050x480	1020x1050x480	1350x1020x330
Weight			kg	71	98/111	119/132	132/143
Power supply (V / Phase / Hz)				V: 230 / 1-ph / 50, Y: 400 / 3-ph / 50			
Heating	A7W35*2	Nominal	kW	4.00	6.50	9.00	12.00
		COP		5.20	4.90	4.70	4.50
	A2W35*2	Nominal	kW	5.0	8.5	11.2	14.0
		COP		3.70	3.51	3.44	3.15
Average climate water outlet 35°C*3		Class		A+++	A+++	A+++	A+++
		ηs		188%	195%/194%	195%/195%	178%/178%
Average climate water outlet 55°C*3		Class		A++	A++	A++	A++
		ηs		131%	141%/141%	136%/136%	133%/133%
DHW 200(L) Load Profile (Average climate)*4		Class		A+	A+	A+	A+
		ηwh		140%	128%	136%	125%
Max outlet water temperature		°C		60	60	60	60
Cooling	A35W7*2	Nominal	kW	4.00	6.50	9.00	11.90
		EER		3.40	3.30	3.30	3.00
	A35W18*2	Nominal	kW	4.00	6.50	9.00	11.10
		EER		5.00	5.00	4.90	4.10
PWL (Heating)*5		dB(A)		61	58	60	67
Max operating current		A		13.0	22.0/11.5	28.0/13.0	35.0/13.0
Breaker size		A		16	25/16	32/16	40/16
Piping	Diameter	Liquid/Gas	mm	-	-	-	-
	Length	Out-In	m	-	-	-	-
	Height	Out-In	m	-	-	-	-
Guaranteed Operating Range	Heating	°C		-20~24	-20~24	-25~24	-28~21
	DHW	°C		-20~35	-20~35	-25~35	-28~35
	Cooling	°C		10~46	10~46	10~46	10~46

\*1 Refrigerant leakage contribute to climate change. Refrigerant with lower global warming potential (GWP) would contribute less to global warming than a refrigerant with higher GWP, if leaked to the atmosphere. This appliance contains a refrigerant fluid with a GWP equal to 675. This means that if 1 kg of this refrigerant fluid would be leaked to the atmosphere, the impact on global warming would be 675 times higher than 1 kg of CO<sub>2</sub> over a period of 100 years. Never try to interfere with the refrigerant circuit yourself or disassemble the product yourself and always ask a professional. The GWP of R32 is 675 in the IPCC 4th Assessment Report.

\*2 Air-to-Water values are measured based on EN14511 (Circulation pump input is not included.).

\*3 ηs values are measured based on Commission Regulation (EU) No 813/2013.

\*4 ηwh values are measured based on EN16147.

\*5 Sound power levels are measured based on EN12102.

**R290**

## PUZ-WZ+E-generation

Model name				PUZ-WZ90V/YAA-W(-BS)	PUZ-WZ115V/YAA-W(-BS)	PUZ-WZ140V/YAA-W(-BS)
Refrigerant				R290*1		
Dimensions		HxWxD	mm	1040 x 1050 x 480		
Weight			kg	102.5/117	102.5/117	119.5/131
Power supply				1φ 230V/3φ 400V		
Heating	A7W35*2	Nominal	kW	8.50	9.50	12.00
		COP		4.32	4.15	4.10
	A2W35*2	Nominal	kW	8.50	9.00	12.00
		COP		3.12	2.99	2.73
Average climate water outlet 35°C*3		Class		A+++	A+++	A+++
		ηs		183%	181%	192%
Average climate water outlet 55°C*3		Class		A++	A++	A++
		ηs		143%	142%	142%
DHW 200(L) Load Profile (Average Climate)*4		Class		A+	A+	A+
		ηwh		137%	137%	129%
Max outlet water temperature		°C		75		
Cooling	A35W7*2	Nominal	kW	5.00	6.00	9.00
		EER		3.30	3.00	3.15
	A35W18*2	Nominal	kW	5.00	6.50	9.00
		EER		4.61	4.00	4.80
PWL (Heating)*5		dB (A)		54	54	55
Max operating current		A		21/12	28/12	35/12
Breaker size		A		25/16	32/16	40/16
Guaranteed operation range	Cooling	°C		10 ~ 46		
	Heating	°C		-25 ~ 24		
	DHW	°C		-25 ~ 46		

\*1. Refrigerant leakage contributes to climate change. Refrigerant with lower global warming potential (GWP) would contribute less to global warming than a refrigerant with higher GWP, if leaked to the atmosphere.

This warming appliance contains a refrigerant liquid with a GWP equal to 3.

This means that if 1 kg of this refrigerant would be leaked to the atmosphere, the impact on global warming would be 3 times higher than 1 kg of CO<sub>2</sub> over a period of 100 years.

Never try to interfere with the refrigerant circuit yourself or disassemble the product yourself and always ask a professional.

The GWP of R290 is 3 in the IPCC 4th Assessment Report.

\*2. Air-to-Water values are measured based on EN14511 (Circulation pump input is not included.).

\*3. ηs values are measured based on EN14825.

\*4. ηwh values are measured based on EN16147.

\*5. Sound power levels are measured based on EN12102.

**R32**

**ZUBADAN**  
New Generation



PUZ-HWM140

**R290**



PUZ-WZ90/115/140V/YAA-W

**POWER INVERTER**



PUZ-WM50 PUZ-WM85/112

# Split Type Specifications

**R32**

## SUZ-S(H)WM+E-generation

Model name				Eco Inverter									
				Standard model			Hyper Heating model		Standard with base heater model				
Refrigerant				R32*1									
Dimensions				SUZ-SWM40VA2	SUZ-SWM60VA2	SUZ-SWM80VA2	SUZ-SWM100VA	SUZ-SHWM40VAH	SUZ-SHWM60VAH	SUZ-SWM80VAH2	SUZ-SWM100VAH		
Weight				714x800x285	714x800x285	880x840x330	880x840x330	714x800x285	880x840x330	880x840x330	880x840x330		
Power supply (V / Phase / Hz)				230 / 1-ph / 50									
Heating	A7W35*2	Nominal	kW	3.0	5.0	6.0	7.5	3.0	5.0	6.0	7.5		
				COP	5.11	4.85	5.10	4.85	4.77	4.95	5.10	4.85	
	A2W35*2	Nominal	kW	4.0	6.0	7.5	9.0	4.0	6.0	7.5	9.0		
				COP	3.90	3.62	3.50	3.12	3.61	3.47	3.31	3.00	
Average climate water outlet 35°C*3				Class	A+++	A+++	A+++	A+++	A+++	A+++	A+++		
				ηS	200%	189%	187%	176%	178%	178%	177%		
Average climate water outlet 55°C*3				Class	A++	A++	A++	A++	A++	A++	A++		
				ηS	135%	136%	135%	134%	126%	128%	129%		
DHW 200L Load Profile*4 *5				Class	A+	A+	A+	A+	A+	A+	A+		
				ηwh	151%	153%	148%	148%	148%	148%	148%		
Max outlet water temperature				°C									
				60	60	60	60	60	60	60	60		
Cooling	A35W7*2	Nominal	kW	4.5	5.0	6.7	7.3	4.5	6.0	6.7	7.3		
				EER	3.31	3.18	3.20	3.00	3.33	3.28	3.20	3.00	
	A35W18*2	Nominal	kW	5.6	6.0	6.7	8.1	5.6	6.0	6.7	8.1		
				EER	4.71	4.65	5.06	4.44	4.70	5.21	5.06	4.44	
PWL (Heating)*6				dB(A)									
				57	60	60	62	58	60	60	62		
Max operating current				A									
				13.5	13.5	17.3	17.3	13.5	17.3	17.3	17.3		
Breaker size				A									
				16	16	20/16*7	20/16*7	16	20/16*7	20/16*7	20/16*7		
Piping	Diameter	Liquid/Gas	mm	6.35/12.7	6.35/12.7	6.35/12.7	6.35/12.7	6.35/12.7	6.35/12.7	6.35/12.7	6.35/12.7		
				Length	Out-In	m	2-26	2-26	2-46	2-46	2-26	2-46	2-46
							Height	Out-In	m	Max. 26	Max. 26	Max. 30	Max. 30
Guaranteed Operating Range	Heating	°C	-25~24	-25~24	-25~24	-25~24				-25~24	-25~24	-25~24	-25~24
			DHW	°C	-25~35	-25~35	-25~35	-25~35	-25~35	-25~35	-25~35	-25~35	
					Cooling	°C	10~46	10~46	10~46	10~46	10~46	10~46	10~46

\*1 Refrigerant leakage contribute to climate change. Refrigerant with lower global warming potential (GWP) would contribute less to global warming than a refrigerant with higher GWP, if leaked to the atmosphere. This appliance contains a refrigerant fluid with a GWP equal to 675. This means that if 1 kg of this refrigerant fluid would be leaked to the atmosphere, the impact on global warming would be 675 times higher than 1 kg of CO<sub>2</sub>, over a period of 100 years. Never try to interfere with the refrigerant circuit yourself or disassemble the product yourself and always ask a professional. The GWP of R32 is 675 in the IPCC 4th Assessment Report.

\*2 Air-to-Water values are measured based on EN14511 (Circulation pump input is not included.).

\*3 ηs values are measured based on Commission Regulation (EU) No 813/2013.

\*4 ηwh values are measured based on EN16147.

\*5 When connecting to E\*\*D.\*\*\*\*E.

\*6 Sound power levels are measured based on EN12102.

\*7 In case of jumper wire cut.

Eco Inverter



SUZ-SWM40VA2  
SUZ-SHWM40VAH  
SUZ-SWM60VA2



SUZ-SHWM60VAH  
SUZ-SWM80VA2  
SUZ-SWM80VAH2  
SUZ-SWM100VA  
SUZ-SWM100VAH

# Split Type Specifications

**R32**

## PUZ-S(H)WM+E-generation

Model name				Standard				ZUBADAN				
				PUZ-SWM80V/YAA	PUZ-SWM100V/YAA	PUZ-SWM120V/YAA	PUZ-SWM140V/YAA	PUZ-SHWM80V/YAA	PUZ-SHWM100V/YAA	PUZ-SHWM120V/YAA	PUZ-SHWM140V/YAA	
Refrigerant				R32*1								
Dimensions				HxWxD mm								
Weight				kg								
Power supply				V: 230 / 1-ph / 50, Y: 400 / 3-ph / 50								
Heating	A7W35*2	Nominal	kW	6.00	8.00	10.00	12.00	6.00	8.00	10.00	12.00	
				COP	5.02	5.02	4.87	4.77	5.05	5.05	4.90	4.85
	A2W35*2	Nominal	kW	8.00	10.00	12.10	14.00	8.00	10.00	12.10	14.00	
				COP	3.70	3.47	3.27	3.27	3.80	3.55	3.35	3.30
Average climate water outlet 35°C*3				Class	A+++	A+++	A+++	A+++	A+++	A+++	A+++	
				ηs	184%/184%	181%/180%	179%/179%	178%/177%	188%/187%	186%/186%	182%/182%	185%/185%
Average climate water outlet 55°C*3				Class	A++	A++	A++	A++	A++	A++	A++	
				ηs	130%/130%	134%/134%	133%/132%	136%/135%	134%/133%	138%/138%	138%/138%	142%/142%
DHW 200L(L) Load Profile (Average climate)*4				Class	A+	A+	A+	A+	A+	A+	A+	
				ηwh	137%	137%	137%	131%	137%	137%	131%	
Max outlet water temperature				°C								
				68							68/70*5	
Cooling	A35W7*2	Nominal	kW	7.10	9.00	11.00	12.50	7.10	9.00	11.00	12.50	
				COP	3.30	3.00	2.86	2.62	3.30	3.00	2.86	2.62
	A35W18*2	Nominal	kW	8.00	10.00	12.00	14.00	8.00	10.00	12.00	14.00	
				COP	4.95	4.50	4.50	3.75	4.95	4.50	4.50	3.75
PWL (Heating)*6				dB(A)								
				54	58	58	58	54	58	58	58	
Max operating current				A								
				17/8	22/9	28/12	28/12	19/8	27/9	28/12	35/12	
Breaker size				A								
				20/16	25/16	32/16	32/16	25/16	30/16	32/16	40/16	
Piping run	Diameter	Gas	mm	12.7 (15.88)*7								
				Liquid	mm	6.35						
	Length	Out-In	m			50	50	30/50*8	30/50*8	50	50	30/50*8
				Height	Out-In	m	30					
Guaranteed operation range	Cooling	°C	10~52									
			Heating	°C	-25~24							
					DHW	°C	-25~42					

\*1 Refrigerant leakage contributes to climate change. Refrigerant with lower global warming potential (GWP) would contribute less to global warming than a refrigerant with higher GWP, if leaked to the atmosphere. This appliance contains a refrigerant fluid with a GWP equal to 675. This means that if 1 kg of this refrigerant would be leaked to the atmosphere, the impact on global warming would be 675 times higher than 1 kg of CO<sub>2</sub>, over a period of 100 years. Never try to interfere with the refrigerant circuit yourself or disassemble the product yourself and always ask a professional. The GWP of R32 is 675 in the IPCC 4th Assessment Report.

\*2 Air-to-Water values are measured or calculated based on EN14511 (Circulation pump input is not included.).

\*3 ηs values are measured based on Commission Regulation (EU) No 813/2013.

\*4 ηwh values are measured based on EN16147:2017.

\*5 When ΔT is 10°C and the piping length is 15m or less.

\*6 Sound power levels are measured based on EN12102:2013.

\*7 A diameter of 15.88 is necessary for cooling operation. Please refer to our installation manual for details.

\*8 For reversible(heating/cooling operation) with PUZ-S(H)WM120/140, the max piping length is 30m.

**R32**

ZUBADAN  
New Generation



PUZ-SHWM80/100/120/140

POWER INVERTER



PUZ-SWM80/100/120/140

# Split Type Specifications

**R410A**

## PUHZ-S(H)W+E-generation

				Power Inverter		ZUBADAN
Model name				PUHZ-SW160YKA(-BS)	PUHZ-SW200YKA(-BS)	PUHZ-SHW230YKA2
Refrigerant				R410A*1		
Dimensions		HxWxD	mm	1338x1050x330	1338x1050x330	1338x1050x330
Weight		kg		136	136	143
Power supply (V / Phase / Hz)				V: 230 / 1-ph / 50, Y: 400 / 3-ph / 50		
Heating	A7W35*2	Nominal	kW	16.0	20.0	23.0
		COP		4.40	4.20	3.65
	A2W35*2	Nominal	kW	16.0	20.0	23.0
		COP		3.11	2.80	2.37
Average climate water outlet 35°C*3		Class	A+++	A++	A++	
		ηs	175%	166%	154%	
Average climate water outlet 55°C*3		Class	A++	A++	A++	
		ηs	126%	131%	125%	
DHW 200L(L)/300L(XL) Load Profile (Average climate)*4		Class	-	-	-	
		ηwh	-	-	-	
Max outlet water temperature		°C		60		
Cooling	A35W7*2	Nominal	kW	16.0	20.0	20.0
		EER		2.76	2.25	2.48
	A35W18*2	Nominal	kW	16.0	20.0	20.0
		EER		4.60	4.20	3.99
PWL (Heating)*5		dB(A)		68	68	68
Max operating current		A		19	21	20
Breaker size		A		32	32	25
Piping	Diameter	Liquid/Gas	mm	9.52/25.4	12.7/25.4	12.7/25.4
	Length	Out-In	m	80		
	Height	Out-In	m	30		
Guaranteed Operating Range	Heating	°C		-20~21	-20~21	-25~21
	DHW	°C		-20~35	-20~35	-25~35
	Cooling	°C		10~46		

- \*1 Refrigerant leakage contribute to climate change. Refrigerant with lower global warming potential (GWP) would contribute less to global warming than a refrigerant with higher GWP, if leaked to the atmosphere. This appliance contains a refrigerant fluid with a GWP equal to 2088. This means that if 1 kg of this refrigerant fluid would be leaked to the atmosphere, the impact on global warming would be 2088 times higher than 1 kg of CO<sub>2</sub>, over a period of 100 years. Never try to interfere with the refrigerant circuit yourself or disassemble the product yourself and always ask a professional. The GWP of R410A is 2088 in the IPCC 4th Assessment Report.
- \*2 Air-to-Water values are measured based on EN14511 (Circulation pump input is not included.).
- \*3 ηs values are measured based on Commission Regulation (EU) No 813/2013.
- \*4 ηwh values are measured based on EN16147.
- \*5 Sound power level is measured based on EN12102:2017.

**R410A**

**ZUBADAN**  
New Generation



PUHZ-SHW230

**POWER INVERTER**



PUHZ-SW160/200

## Optional Parts

### Packaged type

<Indoor unit>

Parts name	Model name	Cylinder	Hydrobox	Remarks
Wireless remote controller	PAR-WT60R-E	✓	✓	
Wireless receiver	PAR-WR61R-E	✓	✓	
Thermistors	PAC-SE41TS-E	✓	✓	For room temp.
	PAC-TH011-E	✓	✓	For buffer and zone (flow and return temp.)
	PAC-TH011TK2-E	-	✓	For tank temp. (5m)
	PAC-TH012HT-E	✓	✓	For boiler and buffer (5m)
Immersion heater	PAC-IH01V2-E	✓	-	1Ph 1kW
	PAC-IH03V2-E	✓	-	1Ph 3kW
Wi-Fi interface	MAC-5871F-E / MAC-5971F-E	✓	✓	
2 Zone kit	PAC-TZ02-E	✓	✓	

<Outdoor unit>

Parts name	Model name	R32 (Power Inverter)			
		PUZ-WM50VHA	PUZ-WM85VAA	PUZ-WM112V/YAA	PUZ-HWM140V/YHA
Connector for drain hose heater signal output	PAC-SE60RA-E	✓	✓	✓	✓
Air discharge guide	PAC-SG59SG-E	✓	-	-	✓
	PAC-SH96SG-E	-	✓*	✓*	-
Air protection guide	PAC-SH63AG-E	✓	-	-	✓
	PAC-SH95AG-E	-	✓*	✓*	-
Attachement	PAC-SJ82AT-E	-	✓	✓	-
Drain socket	PAC-SG61DS-E	✓	✓	✓	-
Centralized drain pan	PAC-SG64DP-E	✓	-	-	-
	PAC-SJ83DP-E	-	✓	✓	-

\*Attachment (PAC-SJ82AT-E) is necessary for the Air Guide.

Parts name	Model name	R290 (Power Inverter)		
		PUZ-WZ90V/YAA-W	PUZ-WZ115V/YAA-W	PUZ-WZ140V/YAA-W
Connector for drain hose heater signal output	PAC-SE60RA-E	✓	✓	✓
	MAC-063RA-E	-	-	-
Air discharge guide	PAC-SG59SG-E	-	-	-
	PAC-SH96SG-E	✓*	✓*	✓*
Air protection guide	PAC-SH63AG-E	-	-	-
	PAC-SH95AG-E	✓*	✓*	✓*
Attachement	PAC-SJ82AT-E	✓	✓	✓
Drain socket	PAC-SG61DS-E	✓	✓	✓
Centralized drain pan	PAC-SG64DP-E	-	-	-
	PAC-SJ83DP-E	✓	✓	✓

\*Attachment (PAC-SJ82AT-E) is necessary for the Air Guide.

## Interface/Flow Temperature Controller

### Packaged type

<Indoor unit>

Parts name	Model name	Description
Flow temperature controller	PAC-IF033B-E	1 PC board w/ Case
	PAC-IF033PCB-E	10 PC board w/o case
System Controllers	PAC-IF072B-E	1 PC board w/ Case
	PAC-IF082B-E	1 PC board w/ Case
Flow sensor	PAC-FS01-E	
Thermistor	PAC-TH011-E	

## Optional Parts

### Split type <Indoor unit>

Parts name	Model name	Cylinder	Hydrobox	Remarks
Wireless remote controller	PAR-WT60R-E	✓	✓	
Wireless receiver	PAR-WR61R-E	✓	✓	
Thermistors	PAC-SE41TS-E	✓	✓	For room temp.
	PAC-TH011-E	✓	✓	For buffer and zone (flow and return temp.)
	PAC-TH011TK2-E	-	✓	For tank temp. (5m)
	PAC-TH012HT-E	✓	✓	For boiler and buffer (5m)
Immersion heater	PAC-IH01V2-E	✓	-	1Ph 1kW
	PAC-IH03V2-E	✓	-	1Ph 3kW
Wi-Fi interface	MAC-S87IF-E /	✓	✓	
	MAC-S97IF-E			
2 Zone kit	PAC-TZ02-E	✓	✓	

## Interface/Flow Temperature Controller

### Split type <Indoor unit>

Parts name	Model name	Description
Capacity step control interface	PAC-IF011B-E	1 PC board w/ Case
Flow temperature controller	PAC-IF032B-E	1 PC board w/ Case
	PAC-IF033B-E	1 PC board w/ Case
	PAC-IF033PCB-E	10 PC board w/o case
System Controllers	PAC-IF071B-E	1 PC board w/ Case
	PAC-IF081B-E	1 PC board w/ Case
Pressure sensor	PAC-PS01-E	For SUZ-SWM40/60/80VA
Flow sensor	PAC-FS01-E	
Thermistor	PAC-TH011-E	

Parts name	Model name	R410A (Power Inverter)		R410A (ZUBADAN)	R32 (PXZ)	
		PUHZ-SW160YKA	PUHZ-SW200YKA	PUHZ-SHW230YKA2	PXZ-4F75VG	PXZ-5F85VG
Connector for Drain Hose	PAC-SE60RA-E	✓	✓	✓	-	-
	MAC-061RA-E	-	-	-	-	-
	MAC-062RA-E	-	-	-	✓	✓
Air discharge Guide	MAC-886SG-E	-	-	-	-	-
	PAC-SH96SG-E*1	✓	✓	✓	-	-
Air Protection Guide	PAC-SH63AG-E	-	-	-	-	-
	PAC-SH95AG-E*1	✓	✓	✓	-	-
Attachment	PAC-SJ82AT-E	-	-	-	-	-
Drain Socket*2	PAC-SG61DS-E	✓	✓	-	-	-
Centralized Drain Pan*2	PAC-SG64DP-E	-	-	-	-	-
	PAC-SH97DP-E	✓	✓	-	-	-
Control/Service Tool	PAC-SK52ST	✓	✓	✓	-	-

\*1 Attachment (PAC-SJ82AT-E) is necessary for the Air guide.

\*2 Cannot be used for cold climate.

### <Outdoor unit>

Parts name	Model name	R32 Eco Inverter							
		SUZ-SWM40VA2	SUZ-SWM60VA2	SUZ-SWM80VA2	SUZ-SWM80VAH2	SUZ-SWM100VA	SUZ-SWM100VAH	SUZ-SHM40VAH	SUZ-SHM60VAH
Connector for Drain Hose	PAC-SE60RA-E	-	-	-	-	-	-	-	-
	MAC-061RA-E	✓	✓	✓	-	✓	-	-	-
	MAC-062RA-E	-	-	-	-	-	-	-	-
Air discharge Guide	MAC-886SG-E	-	-	-	-	-	-	-	-
	PAC-SH96SG-E*1	-	-	-	-	-	-	-	-
Air Protection Guide	PAC-SH63AG-E	-	-	-	-	-	-	-	-
	PAC-SH95AG-E*1	-	-	-	-	-	-	-	-
Attachment	PAC-SJ82AT-E	-	-	-	-	-	-	-	-
Drain Socket*2	PAC-SG61DS-E	-	-	-	-	-	-	-	-
Centralized Drain Pan*2	PAC-SG64DP-E	-	-	-	-	-	-	-	-
	PAC-SH97DP-E	-	-	-	-	-	-	-	-
Control/Service Tool	PAC-SK52ST	-	-	-	-	-	-	-	-

\*1 Attachment (PAC-SJ82AT-E) is necessary for the Air guide.

\*2 Cannot be used for cold climate.

Parts name	Model name	R32 Reversible (Power Inverter)				R32 Reversible (ZUBADAN)			
		PUZ-SWM80V/YAA	PUZ-SWM100V/YAA	PUZ-SWM120V/YAA	PUZ-SWM140V/YAA	PUZ-SHWM80V/YAA	PUZ-SHWM100V/YAA	PUZ-SHWM120V/YAA	PUZ-SHWM140V/YAA
Connector for Drain Hose	PAC-SE60RA-E	✓	✓	✓	✓	✓	✓	✓	✓
	MAC-061RA-E	-	-	-	-	-	-	-	-
	MAC-062RA-E	-	-	-	-	-	-	-	-
Air discharge Guide	MAC-886SG-E	-	-	-	-	-	-	-	-
	PAC-SH96SG-E*1	✓	✓	✓	✓	✓	✓	✓	✓
Air Protection Guide	PAC-SH63AG-E	-	-	-	-	-	-	-	-
	PAC-SH95AG-E*1	✓	✓	✓	✓	✓	✓	✓	✓
Attachment	PAC-SJ82AT-E	✓	✓	✓	✓	✓	✓	✓	✓
Drain Socket*2	PAC-SG61DS-E	✓	✓	✓	✓	✓	✓	✓	✓
Centralized Drain Pan*2	PAC-SG64DP-E	-	-	-	-	-	-	-	-
	PAC-SH97DP-E	-	-	-	-	-	-	-	-
Control/Service Tool	PAC-SK52ST	✓	✓	✓	✓	✓	✓	✓	✓

\*1 Attachment (PAC-SJ82AT-E) is necessary for the Air guide.

\*2 Cannot be used for cold climate.

# E Generation

## Combination Table

### Packaged indoor/outdoor unit

Packaged indoor/outdoor unit Combination		R290			R32			ZUBA DAN
		Power inverter			Power inverter			
		PUZ-WZ80V/YAA	PUZ-WZ115V/YAA	PUZ-WZ140V/YAA	PUZ-WM50VHA	PUZ-WM85V/YAA	PUZ-WM112V/YAA	
Reversible Cylinder	ERPT17X-VM2E	●			●	●		
	ERPT20X-VM2E	●	●	●	●	●	●	●
	ERPT20X-YM9E	●	●	●	●	●	●	●
	ERPT30X-VM2EE	●	●	●		●	●	●
	ERPT30X-YM9EE	●	●	●		●	●	●
Reversible Hydrobox	ERPX-VM2E	●	●	●	●	●	●	●
	ERPX-YM9E	●	●	●	●	●	●	●

● : Combination is available.  
 Blank: Combination is NOT available.

# E Generation

### Split indoor/outdoor unit

Split indoor/outdoor unit Combination		R32												R410A		ATA/ATW Hybrid system									
		eco inverter						Power inverter				ZUBADAN		Power inverter	ZUBA DAN	PXZ	PUMY								
		SUZ-SWM40VA2	SUZ-SWM60VA2	SUZ-SWM80VA2	SUZ-SWM100VA	SUZ-SHWM40VAH	SUZ-SHWM60VAH	SUZ-SWM80VAH2	SUZ-SWM100VAH	PUZ-SWM80V/YAA	PUZ-SWM100V/YAA	PUZ-SWM120V/YAA	PUZ-SWM140V/YAA	PUZ-SHWM80V/YAA	PUZ-SHWM100V/YAA	PUZ-SHWM120V/YAA	PUZ-SHWM140V/YAA	PUHZ-SW160YKA	PUHZ-SW200YKA	PUHZ-SHW230YKA2	PXZ-4F75VG	PXZ-5F85VG	PUMY-P112V/YKMIEI6/5	PUMY-P125V/YKMIEI6/5	PUMY-P140V/YKMIEI6/5
Reversible Cylinder	ERST17D-VM2E	●	●	●	●	●	●	●													▲	▲			
	ERST20D-VM2E	●	●	●	●	●	●	●														▲	▲		
	ERST20D-YM9E	●	●	●	●	●	●	●														▲	▲		
	ERST30D-VM2EE	●	●	●	●	●	●	●														▲	▲		
	ERST30D-YM9EE	●	●	●	●	●	●	●														▲	▲		
	ERST20F-VM2E								●	●	●	●	●	●	●	●									
	ERST20F-YM9E								●	●	●	●	●	●	●	●									
	ERST30F-VM2EE								●	●	●	●	●	●	●	●									
	ERST30F-YM9EE								●	●	●	●	●	●	●	●									
ERST20C-VM2E																							●	●	●
Reversible Hydrobox	ERSD-VM2E	●	●	●	●	●	●	●														▲	▲		
	ERSD-YM9E	●	●	●	●	●	●	●														▲	▲		
	ERSF-VM2E								●	●	●	●	●	●	●										
	ERSF-YM9E								●	●	●	●	●	●	●										
	ERSC-VM2E																						●	●	●
	ERSC-YM9E																						●	●	●
	ERSE-YM9EE																●	●	●						
ERSE-MEE																●	●	●							

● : Combination is available.  
 ▲ : Combination is possible but cooling function is NOT available.  
 Blank: Combination is NOT available.

# MELCloud Home (Wi-Fi Interface) for ecodan

## MELCloud Home for Fast, Easy Remote Control and Monitoring of Your ecodan

MELCloud Home\*<sup>1</sup> is a new Cloud-based solution for controlling ecodan either locally or remotely by computer, tablet or smartphone via the Internet. Setting up and remotely operating your ecodan heating system via MELCloud Home is simple and straight forward. All you need is wireless computer connectivity in your home or the building where the ecodan is installed and an Internet connection on your mobile or fixed terminal. To set up the system, the router and the ecodan WiFi interface must be paired, and this is done simply and quickly using the WPS button found on all mainstream routers.

You can control and check ecodan via MELCloud Home from virtually anywhere an Internet connection is available. That means, thanks to MELCloud Home, you can use ecodan much more easily and conveniently.



## Key Control and Monitoring Features

- 1 Turn system on/off**
- 2 See status of each of your heating zones & adjust set points**
- 3 See the status of your hot water cylinder & boost remotely**
- 4 Live weather feed from ecodan location**
  - Holiday mode - Set system parameters while away
  - Schedule timer - Set 7 day weekly schedule
  - Frost protection - Set system to run at minimum temperature
  - Error status
- 5 Check energy usage report\*** \*Additional metering hardware is required.

\*<sup>1</sup> Check availability and compatibility of MelCloud Home in your country.

## Seasonal Space Heating Energy Efficiency Class are All A+ or Above!!

Outdoor unit	Indoor unit	For medium-temperature application							For low-temperature application										
		Seasonal space heating energy efficiency class	Water heating energy efficiency class	Rated heat output under average climate conditions		Seasonal space heating energy efficiency under average climate conditions		Water heating energy efficiency under average climate conditions*1	Sound power level L <sub>WA</sub> indoor	Sound power level L <sub>WA</sub> outdoor	Seasonal space heating energy efficiency class	Water heating energy efficiency class	Rated heat output under average climate conditions		Seasonal space heating energy efficiency under average climate conditions		Water heating energy efficiency under average climate conditions*1	Sound power level L <sub>WA</sub> indoor	Sound power level L <sub>WA</sub> outdoor
				kW	%	%	%						kW	%	%	%			
PUZ-WM50VHA	EHPT17X-****E	A++	A+	5	129	115*2	40	61	A+++	A+	5	183	115*2	40	61				
	ERPT17X-****E	A++	A+	5	131	115*2	40	61	A+++	A+	5	188	115*2	40	61				
	EHPT20X-****E(W)	A++	A+	5	129	140*2	40	61	A+++	A+	5	183	140*2	40	61				
	ERPT20X-****E	A++	A+	5	131	140*2	40	61	A+++	A+	5	188	140*2	40	61				
	ERPX-****E	A++	-	5	131	-	40	61	A+++	-	5	188	-	40	61				
PUZ-WM85VAA	EHPT17X-****E	A++	A+	9	140/139	115*2	40	58	A+++	A+	9	192/190	115*2	40	58				
	ERPT17X-****E	A++	A+	9	141/141	115*2	40	58	A+++	A+	9	195/194	115*2	40	58				
	EHPT20X-****E(W)	A++	A+	9	140/139	128*2	40	58	A+++	A+	9	192/190	128*2	40	58				
	ERPT20X-****E	A++	A+	9	141/141	128*2	40	58	A+++	A+	9	195/194	128*2	40	58				
	EHPT30X-****E	A++	A	9	140/139	113*2	40	58	A+++	A	9	192/190	113*2	40	58				
	ERPT30X-****E	A++	A	9	141/141	113*2	40	58	A+++	A	9	195/194	113*2	40	58				
	ERPX-****E	A++	-	9	141/141	-	40	58	A+++	-	9	195/194	-	40	58				
PUZ-WM112V/YAA	EHPT20X-****E(W)	A++	A+	10	135/134	136*2	40	60	A+++	A+	10	193/191	136*2	40	60				
	ERPT20X-****E	A++	A+	10	136/136	136*2	40	60	A+++	A+	10	195/195	136*2	40	60				
	EHPT30X-****E	A++	A	10	135/134	112*2	40	60	A+++	A	10	193/191	112*2	40	60				
	ERPT30X-****E	A++	A	10	136/136	112*2	40	60	A+++	A	10	195/195	112*2	40	60				
	ERPX-****E	A++	-	10	136/136	-	40	60	A+++	-	10	195/195	-	40	60				
PUZ-HWM140V/YHA	EHPT20X-****E(W)	A++	A+	14	132/131	125	40	67	A+++	A+	14	176/175	125	40	67				
	ERPT20X-****E	A++	A+	14	133/133	125	40	67	A+++	A+	14	178/178	125	40	67				
	EHPT30X-****E	A++	A	14	132/131	108	40	67	A+++	A	14	176/175	108	40	67				
	ERPT30X-****E	A++	A	14	133/133	108	40	67	A+++	A	14	178/178	108	40	67				
	ERPX-****E	A++	-	14	133/133	-	40	67	A+++	-	14	178/178	-	40	67				
PUZ-WZ90V/YAA-W	EHPT17X-****E	A++	A+	8.0	141	121	40	54	A+++	A+	8.0	179	121	40	54				
	ERPT17X-****E	A++	A+	8.0	143	121	40	54	A+++	A+	8.0	183	121	40	54				
	EHPT20X-****E(W)	A++	A+	8.0	141	137	40	54	A+++	A+	8.0	179	137	40	54				
	ERPT20X-****E	A++	A+	8.0	143	137	40	54	A+++	A+	8.0	183	137	40	54				
	EHPT30X-****E	A++	A	8.0	141	114	40	54	A+++	A	8.0	179	114	40	54				
	ERPT30X-****E	A++	A	8.0	143	114	40	54	A+++	A	8.0	183	114	40	54				
	ERPX-****E	A++	-	8.0	143	-	40	54	A+++	-	8.0	183	-	40	54				
PUZ-WZ115V/YAA-W	EHPT20X-****E(W)	A++	A+	9.5	140	137	40	54	A+++	A+	9.5	177	137	40	54				
	ERPT20X-****E	A++	A+	9.5	142	137	40	54	A+++	A+	9.5	181	137	40	54				
	EHPT30X-****E	A++	A	9.5	140	114	40	54	A+++	A	9.5	177	114	40	54				
	ERPT30X-****E	A++	A	9.5	142	114	40	54	A+++	A	9.5	181	114	40	54				
	ERPX-****E	A++	-	9.5	142	-	40	54	A+++	-	9.5	181	-	40	54				
PUZ-WZ140V/YAA-W	EHPT20X-****E(W)	A++	A+	11.0	140	129	40	55	A+++	A+	11.0	188	129	40	55				
	ERPT20X-****E	A++	A+	11.0	142	129	40	55	A+++	A+	11.0	192	129	40	55				
	EHPT30X-****E	A++	A+	11.0	140	123	40	55	A+++	A+	11.0	188	123	40	55				
	ERPT30X-****E	A++	A+	11.0	142	123	40	55	A+++	A+	11.0	192	123	40	55				
	ERPX-****E	A++	-	11.0	142	-	40	55	A+++	-	11.0	192	-	40	55				

\*1 η<sub>wh</sub> values are measured based on EN16147:2017.

\*2 η<sub>wh</sub> values are measured based on EN16147:2022.

Outdoor unit	Indoor unit	For medium-temperature application							For low-temperature application										
		Seasonal space heating energy efficiency class	Water heating energy efficiency class	Rated heat output under average climate conditions		Seasonal space heating energy efficiency under average climate conditions		Water heating energy efficiency under average climate conditions*1	Sound power level L <sub>WA</sub> indoor	Sound power level L <sub>WA</sub> outdoor	Seasonal space heating energy efficiency class	Water heating energy efficiency class	Rated heat output under average climate conditions		Seasonal space heating energy efficiency under average climate conditions		Water heating energy efficiency under average climate conditions*1	Sound power level L <sub>WA</sub> indoor	Sound power level L <sub>WA</sub> outdoor
				kW	%	%	%						kW	%	%	%			
SUZ-SWM40VA2	EHST17D-****E	A++	A+	5	133	136	41	57	A+++	A+	5	196	136	41	57				
	ERST17D-****E	A++	A+	5	135	136	41	57	A+++	A+	5	200	136	41	57				
	ERST17D-***BE	A++	A+	5	135	136	41	57	A+++	A+	5	200	136	41	57				
	EHST20D-****E	A++	A+	5	133	151	41	57	A+++	A+	5	196	151	41	57				
	ERST20D-****E	A++	A+	5	135	151	41	57	A+++	A+	5	200	151	41	57				
	EHST30D-****E	A++	A+	5	133	126	41	57	A+++	A+	5	196	126	41	57				
	ERST30D-****E	A++	A+	5	135	126	41	57	A+++	A+	5	200	126	41	57				
	EHSD-****E	A++	-	5	133	-	41	57	A+++	-	5	196	-	41	57				
ERSD-****E	A++	-	5	135	-	41	57	A+++	-	5	200	-	41	57					
SUZ-SHWM40VAH	EHST17D-****E	A+	A+	5	124	135	41	58	A++	A+	5	172	135	41	58				
	ERST17D-****E	A++	A+	5	126	135	41	58	A+++	A+	5	176	135	41	58				
	ERST17D-***BE	A++	A+	5	126	135	41	58	A+++	A+	5	176	135	41	58				
	EHST20D-****E	A+	A+	5	124	153	41	58	A++	A+	5	172	153	41	58				
	ERST20D-****E	A++	A+	5	126	153	41	58	A+++	A+	5	176	153	41	58				
	EHST30D-****E	A+	A+	5	124	125	41	58	A++	A+	5	172	125	41	58				
	ERST30D-****E	A++	A+	5	126	125	41	58	A+++	A+	5	176	125	41	58				
	EHSD-****E	A+	-	5	124	-	41	58	A++	-	5	172	-	41	58				
ERSD-****E	A++	-	5	126	-	41	58	A+++	-	5	176	-	41	58					
SUZ-SWM60VA2	EHST17D-****E	A++	A+	6	134	135	41	60	A+++	A+	6	185	135	41	60				
	ERST17D-****E	A++	A+	6	136	135	41	60	A+++	A+	6	189	135	41	60				
	ERST17D-***BE	A++	A+	6	136	135	41	60	A+++	A+	6	189	135	41	60				
	EHST20D-****E	A++	A+	6	134	153	41	60	A+++	A+	6	185	153	41	60				
	ERST20D-****E	A++	A+	6	136	153	41	60	A+++	A+	6	189	153	41	60				
	EHST30D-****E	A++	A+	6	134	125	41	60	A+++	A+	6	185	125	41	60				
	ERST30D-****E	A++	A+	6	136	125	41	60	A+++	A+	6	189	125	41	60				
	EHSD-****E	A++	-	6	134	-	41	60	A+++	-	6	185	-	41	60				
ERSD-****E	A++	-	6	136	-	41	60	A+++	-	6	189	-	41	60					
SUZ-SHWM60VAH	EHST17D-****E	A++	A+	6	126	140	41	60	A+++	A+	6	175	140	41	60				
	ERST17D-****E	A++	A+	6	128	140	41	60	A+++	A+	6	178	140	41	60				
	ERST17D-***BE	A++	A+	6	128	140	41	60	A+++	A+	6	178	140	41	60				
	EHST20D-****E	A++	A+	6	126	148	41	60	A+++	A+	6	175	148	41	60				
	ERST20D-****E	A++	A+	6	128	148	41	60	A+++	A+	6	178	148	41	60				
	EHST30D-****E	A++	A+	6	126	125	41	60	A+++	A+	6	175	125	41	60				
	ERST30D-****E	A++	A+	6	128	125	41	60	A+++	A+	6	178	125	41	60				
	EHSD-****E	A++	-	6	126	-	41	60	A+++	-	6	175	-	41	60				
ERSD-****E	A++	-	6	128	-	41	60	A+++	-	6	178	-	41	60					
SUZ-SWM80VA2	EHST17D-****E	A++	A+	7	133	140	41	60	A+++	A+	7	183	140	41	60				
	ERST17D-****E	A++	A+	7	135	140	41	60	A+++	A+	7	187	140	41	60				
	ERST17D-***BE	A++	A+	7	135	140	41	60	A+++	A+	7	187	140	41	60				
	EHST20D-****E	A++	A+	7	133	148	41	60	A+++	A+	7	183	148	41	60				
	ERST20D-****E	A++	A+	7	135	148	41	60	A+++	A+	7	187	148	41	60				
	EHST30D-****E	A++	A+	7	133	125	41	60	A+++	A+	7	183	125	41	60				
	ERST30D-****E	A++	A+	7	135	125	41	60	A+++	A+	7	187	125	41	60				
	EHSD-****E	A++	-	7	133	-	41	60	A+++	-	7	183	-	41	60				
ERSD-****E	A++	-	7	135	-	41	60	A+++	-	7	187	-	41	60					

\*1 qwh values are measured based on EN16147:2017.

## Seasonal Space Heating Energy Efficiency Class are All A+ or Above!!

Outdoor unit	Indoor unit	For medium-temperature application							For low-temperature application						
		Seasonal space heating energy efficiency class	Water heating energy efficiency class	Rated heat output under average climate conditions	Seasonal space heating energy efficiency under average climate conditions	Water heating energy efficiency under average climate conditions*1	Sound power level L <sub>WA</sub> indoor	Sound power level L <sub>WA</sub> outdoor	Seasonal space heating energy efficiency class	Water heating energy efficiency class	Rated heat output under average climate conditions	Seasonal space heating energy efficiency under average climate conditions	Water heating energy efficiency under average climate conditions*1	Sound power level L <sub>WA</sub> indoor	Sound power level L <sub>WA</sub> outdoor
				kW	%	%	dB	dB			kW	%	%	dB	dB
SUZ-SWM80VAH2	EHST17D-****E	A++	A+	7	128	140	41	60	A+++	A+	7	175	140	41	60
	ERST17D-****E	A++	A+	7	130	140	41	60	A+++	A+	7	178	140	41	60
	ERST17D-***BE	A++	A+	7	130	140	41	60	A+++	A+	7	178	140	41	60
	EHST20D-****E	A++	A+	7	128	148	41	60	A+++	A+	7	175	148	41	60
	ERST20D-****E	A++	A+	7	130	148	41	60	A+++	A+	7	178	148	41	60
	EHST30D-****E	A++	A+	7	128	125	41	60	A+++	A+	7	175	125	41	60
	ERST30D-****E	A++	A+	7	130	125	41	60	A+++	A+	7	178	125	41	60
	EHSD-****E	A++	-	7	128	-	41	60	A+++	-	7	175	-	41	60
	ERSD-****E	A++	-	7	130	-	41	60	A+++	-	7	178	-	41	60
SUZ-SWM100VA	EHST17D-****E	A++	A+	8	133	140	41	62	A+++	A+	8	179	140	41	62
	ERST17D-****E	A++	A+	8	134	140	41	62	A+++	A+	8	182	140	41	62
	ERST17D-***BE	A++	A+	8	134	140	41	62	A+++	A+	8	182	140	41	62
	EHST20D-****E	A++	A+	8	133	148	41	62	A+++	A+	8	179	148	41	62
	ERST20D-****E	A++	A+	8	134	148	41	62	A+++	A+	8	182	148	41	62
	EHST30D-****E	A++	A+	8	133	125	41	62	A+++	A+	8	179	125	41	62
	ERST30D-****E	A++	A+	8	134	125	41	62	A+++	A+	8	182	125	41	62
	EHSD-****E	A++	-	8	133	-	41	62	A+++	-	8	179	-	41	62
	ERSD-****E	A++	-	8	134	-	41	62	A+++	-	8	182	-	41	62
SUZ-SWM100VAH	EHST17D-****E	A++	A+	8	127	140	41	62	A++	A+	8	174	140	41	62
	ERST17D-****E	A++	A+	8	129	140	41	62	A+++	A+	8	177	140	41	62
	ERST17D-***BE	A++	A+	8	129	140	41	62	A+++	A+	8	177	140	41	62
	EHST20D-****E	A++	A+	8	127	148	41	62	A++	A+	8	174	148	41	62
	ERST20D-****E	A++	A+	8	129	148	41	62	A+++	A+	8	177	148	41	62
	EHST30D-****E	A++	A+	8	127	125	41	62	A++	A+	8	174	125	41	62
	ERST30D-****E	A++	A+	8	129	125	41	62	A+++	A+	8	177	125	41	62
	EHSD-****E	A++	-	8	127	-	41	62	A++	-	8	174	-	41	62
	ERSD-****E	A++	-	8	129	-	41	62	A+++	-	8	177	-	41	62
PUZ-SWM80V/YAA	ERST17D-***BE	A++	A+	8	130/130	126	41	54	A+++	A+	8	184/183	126	41	54
	ERST20F-****E	A++	A+	8	130/130	137	41	54	A+++	A+	8	184/184	137	41	54
	ERST30F-****E	A++	A+	8	130/130	125	41	54	A+++	A+	8	184/184	125	41	54
	ERSF-****E	A++	-	8	130/130	-	41	54	A+++	-	8	184/184	-	41	54
PUZ-SWM100V/YAA	ERST20F-****E	A++	A+	10	134/134	137	41	58	A+++	A+	10	181/180	137	41	58
	ERST30F-****E	A++	A+	10	134/134	125	41	58	A+++	A+	10	181/180	125	41	58
	ERSF-****E	A++	-	10	134/134	-	41	58	A+++	-	10	181/180	-	41	58
PUZ-SWM120V/YAA	ERST20F-****E	A++	A+	12	133/132	137	41	58	A+++	A+	12	179/179	137	41	58
	ERST30F-****E	A++	A+	12	133/132	125	41	58	A+++	A+	12	179/179	125	41	58
	ERSF-****E	A++	-	12	133/132	-	41	58	A+++	-	12	179/179	-	41	58
PUZ-SWM140V/YAA	ERST20F-****E	A++	A+	14	136/135	131	41	58	A+++	A+	14	178/177	131	41	58
	ERST30F-****E	A++	A	14	136/135	112	41	58	A+++	A	14	178/177	112	41	58
	ERSF-****E	A++	-	14	136/135	-	41	58	A+++	-	14	178/177	-	41	58
PUZ-SHWM80V/YAA	ERST17D-***BE	A++	A+	8	133/133	126	41	54	A+++	A+	8	187/187	126	41	54
	ERST20F-****E	A++	A+	8	134/133	137	41	54	A+++	A+	8	188/187	137	41	54
	ERST30F-****E	A++	A+	8	134/133	125	41	54	A+++	A+	8	188/187	125	41	54
	ERSF-****E	A++	-	8	134/133	-	41	54	A+++	-	8	188/187	-	41	54
PUZ-SHWM100V/YAA	ERST20F-****E	A++	A+	10	138/138	137	41	58	A+++	A+	10	186/186	137	41	58
	ERST30F-****E	A++	A+	10	138/138	125	41	58	A+++	A+	10	186/186	125	41	58
	ERSF-****E	A++	-	10	138/138	-	41	58	A+++	-	10	186/186	-	41	58

\*1 η<sub>wh</sub> values are measured based on EN16147:2017.

Outdoor unit	Indoor unit	For medium-temperature application							For low-temperature application										
		Seasonal space heating energy efficiency class	Water heating energy efficiency class	Rated heat output under average climate conditions		Seasonal space heating energy efficiency under average climate conditions		Water heating energy efficiency under average climate conditions*1	Sound power level L <sub>WA</sub> indoor	Sound power level L <sub>WA</sub> outdoor	Seasonal space heating energy efficiency class	Water heating energy efficiency class	Rated heat output under average climate conditions		Seasonal space heating energy efficiency under average climate conditions		Water heating energy efficiency under average climate conditions*1	Sound power level L <sub>WA</sub> indoor	Sound power level L <sub>WA</sub> outdoor
				kW	%	%	%						kW	%	%	%			
PUZ-SHWM120V/YAA	ERST20F-****E	A++	A+	12	138/138	137	41	58	A+++	A+	12	182/182	137	41	58				
	ERST30F-****E	A++	A+	12	138/138	125	41	58	A+++	A+	12	182/182	125	41	58				
	ERSF-****E	A++	-	12	138/138	-	41	58	A+++	-	12	182/182	-	41	58				
PUZ-SHWM140V/YAA	ERST20F-****E	A++	A+	14	142/142	131	41	58	A+++	A+	14	185/185	131	41	58				
	ERST30F-****E	A++	A	14	142/142	112	41	58	A+++	A	14	185/185	112	41	58				
	ERSF-****E	A++	-	14	142/142	-	41	58	A+++	-	14	185/185	-	41	58				
PUMY-P112VKM6	ERST20C-****E	A+	A	11	121	105	40	69	A++	A	11	168	105	40	69				
	ERSC-****E	A+	-	11	121	-	40	69	A++	-	11	168	-	40	69				
PUMY-P125VKM6	ERST20C-****E	A+	A	11	121	105	40	69	A++	A	11	168	105	40	69				
	ERSC-****E	A+	-	11	121	-	40	69	A++	-	11	168	-	40	69				
PUMY-P140VKM6	ERST20C-****E	A+	A	11	121	105	40	69	A++	A	11	168	105	40	69				
	ERSC-****E	A+	-	11	121	-	40	69	A++	-	11	168	-	40	69				
PUMY-P112YKM5	ERST20C-****E	A+	A	11	121	105	40	69	A++	A	11	168	105	40	69				
	ERSC-****E	A+	-	11	121	-	40	69	A++	-	11	168	-	40	69				
PUMY-P125YKM5	ERST20C-****E	A+	A	11	121	105	40	69	A++	A	11	168	105	40	69				
	ERSC-****E	A+	-	11	121	-	40	69	A++	-	11	168	-	40	69				
PUMY-P140YKM5	ERST20C-****E	A+	A	11	121	105	40	69	A++	A	11	168	105	40	69				
	ERSC-****E	A+	-	11	121	-	40	69	A++	-	11	168	-	40	69				
PXZ-4F75VG	EHST17D-****E	A+	A+	6	113	121	41	67	A++	A+	6	154	121	41	67				
	ERST17D-****E	A+	A+	6	113	121	41	67	A++	A+	6	154	121	41	67				
	EHST20D-****E	A+	A+	6	113	130	41	67	A++	A+	6	154	130	41	67				
	ERST20D-****E	A+	A+	6	113	130	41	67	A++	A+	6	154	130	41	67				
	EHST30D-****E	A+	A	6	113	116	41	67	A++	A	6	154	116	41	67				
	ERST30D-****E	A+	A	6	113	116	41	67	A++	A	6	154	116	41	67				
	EHSD-****E	A+	-	6	113	-	41	67	A++	-	6	154	-	41	67				
	ERSD-****E	A+	-	6	113	-	41	67	A++	-	6	154	-	41	67				
PXZ-5F85VG	EHST17D-****E	A+	A+	7	111	125	41	64	A++	A+	7	157	125	41	64				
	ERST17D-****E	A+	A+	7	111	125	41	64	A++	A+	7	157	125	41	64				
	EHST20D-****E	A+	A+	7	111	135	41	64	A++	A+	7	157	135	41	64				
	ERST20D-****E	A+	A+	7	111	135	41	64	A++	A+	7	157	135	41	64				
	EHST30D-****E	A+	A	7	111	119	41	64	A++	A	7	157	119	41	64				
	ERST30D-****E	A+	A	7	111	119	41	64	A++	A	7	157	119	41	64				
	EHSD-****E	A+	-	7	111	-	41	64	A++	-	7	157	-	41	64				
	ERSD-****E	A+	-	7	111	-	41	64	A++	-	7	157	-	41	64				
PUHZ-SW160YKA	ERSE-***E	A++	-	14	126	-	45	68	A+++	-	15	175	-	45	68				
PUHZ-SW200YKA	ERSE-***E	A++	-	16	131	-	45	68	A++	-	17	166	-	45	68				
PUHZ-SHW230YKA2	ERSE-***E	A++	-	23	125	-	45	68	A++	-	23	154	-	45	68				

\*1 η<sub>wh</sub> values are measured based on EN16147:2017.

# Refrigerant Amount

	Model Name	Refrigerant		Pre-charged quantity	
			GWP	Weight (kg)	CO <sub>2</sub> equivalent (t)
PUMY	PUMY-P112VKM5(-BS)	R410A	2088	4.8	10.02
	PUMY-P125VKM5(-BS)	R410A	2088	4.8	10.02
	PUMY-P140VKM5(-BS)	R410A	2088	4.8	10.02
ATW Packaged	PUZ-WM50VHA	R32	675	2	1.35
	PUZ-WM85V/YAA	R32	675	2.2	1.49
	PUZ-WM112V/YAA	R32	675	3	2.03
	PUZ-HWM140V/YHA	R32	675	3.3	2.23
	PUZ-WZ90V/YAA	R290	3	0.6	0.0018
	PUZ-WZ115V/YAA	R290	3	0.6	0.0018
	PUZ-WZ140V/YAA	R290	3	0.82	0.0025
ATW Split	SUZ-SWM40VA2	R32	675	0.8	0.54
	SUZ-SWM60VA2	R32	675	0.8	0.54
	SUZ-SWM80VA2	R32	675	1.1	0.74
	SUZ-SWM100VA	R32	675	1.1	0.74
	PUD-SWM80V/YAA	R32	675	1.3	0.88
	PUD-SWM100V/YAA	R32	675	1.6	1.08
	PUD-SWM120V/YAA	R32	675	1.6	1.08
	PUD-SHWM80V/YAA	R32	675	1.4	0.95
	PUD-SHWM100V/YAA	R32	675	1.7	1.15
	PUD-SHWM120V/YAA	R32	675	1.7	1.15
	PUD-SHWM140YAA	R32	675	1.7	1.15
	PUHZ-SW160YKA	R410A	2088	7.1	14.82
	PUHZ-SW200YKA	R410A	2088	7.7	16.08
	PUHZ-SHW230YKA2	R410A	2088	7.1	14.82
	PUZ-SWM80VAA	R32	675	1.8	1.22
	PUZ-SWM100V/YAA	R32	675	1.8	1.22
	PUZ-SWM120V/YAA	R32	675	1.8	1.22
	PUZ-SWM140V/YAA	R32	675	1.8	1.22
	PUZ-SHWM80V/YAA	R32	675	1.8	1.22
	PUZ-SHWM100V/YAA	R32	675	1.8	1.22
	PUZ-SHWM120V/YAA	R32	675	1.8	1.22
PUZ-SHWM140V/YAA	R32	675	1.8	1.22	
Multi Comfort	PXZ-4F75VG(2)	R32	675	2.4	1.62
	PXZ-5F85VG(2)	R32	675	2.4	1.62





PXZ

PXZ-4F75VG/VG2

Unit : mm

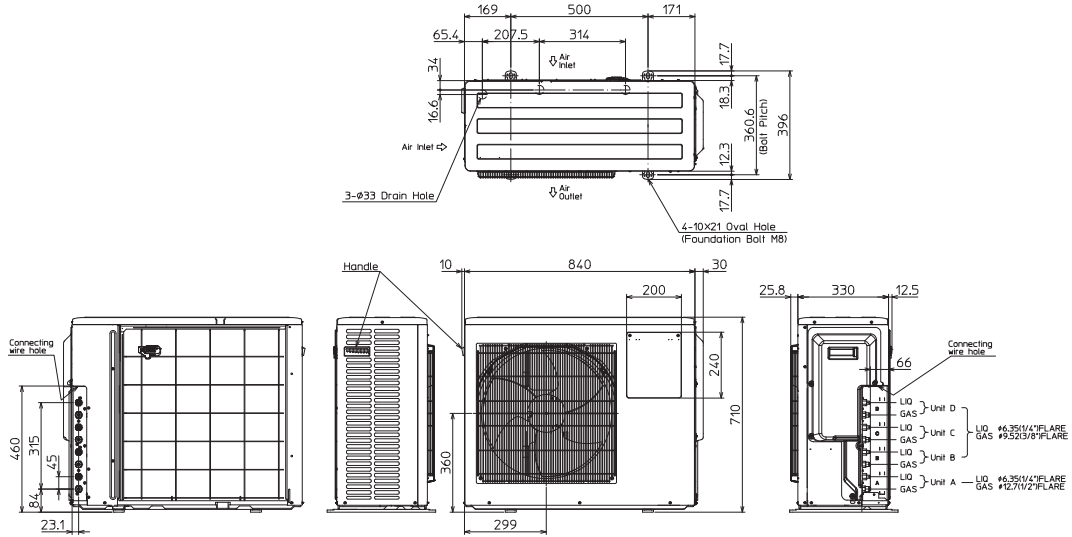

PXZ-5F85VG/VG2

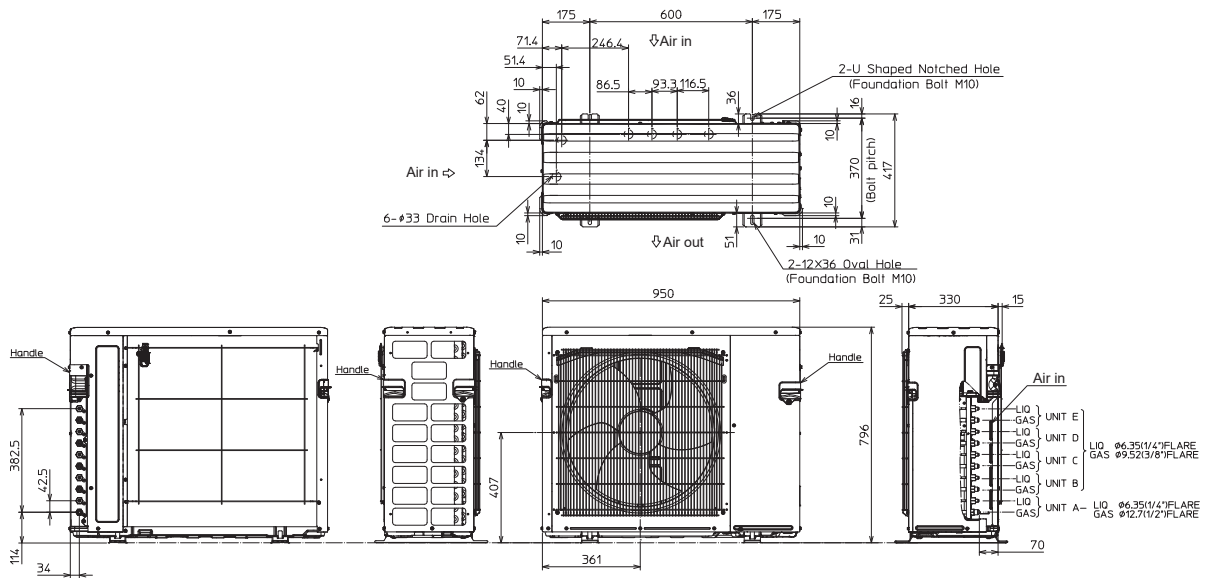

PUMY-P

Unit : mm

PUMY-P112VKM6/7  
 PUMY-P125VKM6/7  
 PUMY-P140VKM6/7

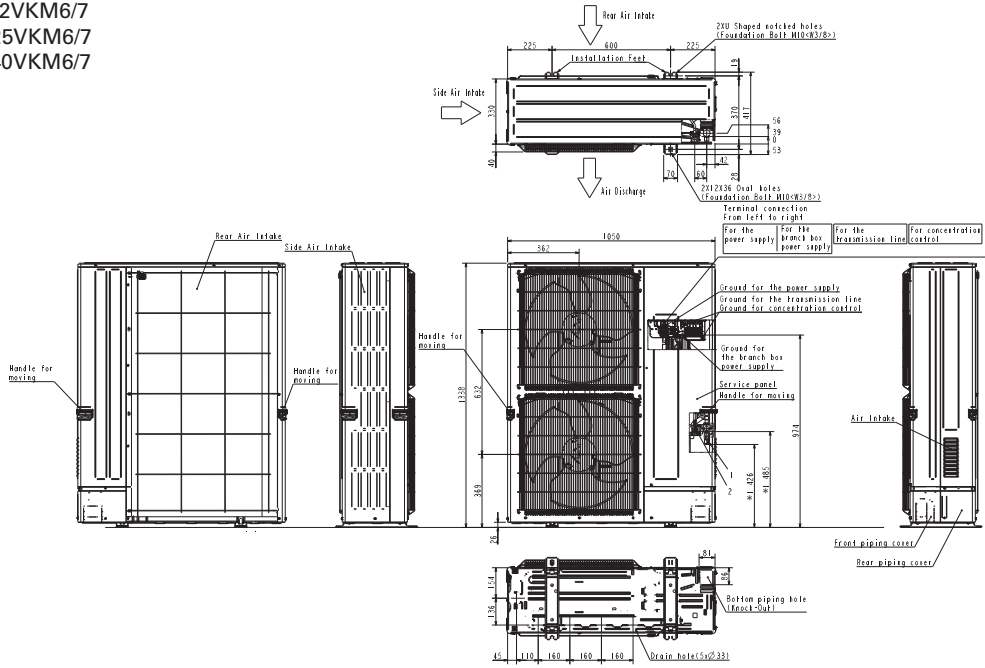

PUMY-P112YKM5/7  
 PUMY-P125YKM5/7  
 PUMY-P140YKM5/7

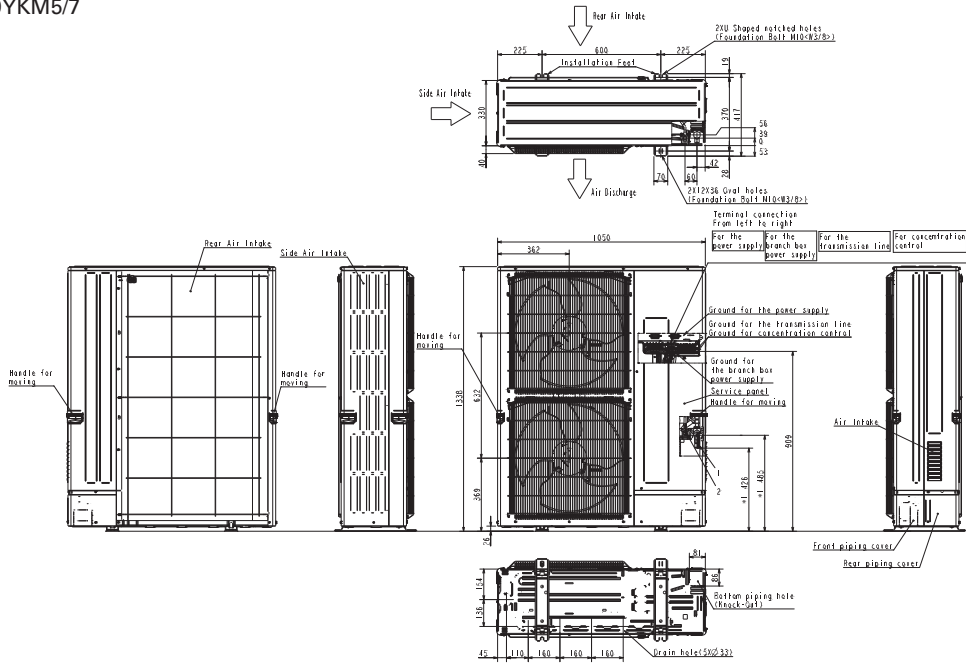

PUHZ-S(H)W

Unit : mm

PUHZ-SW160/200YKA

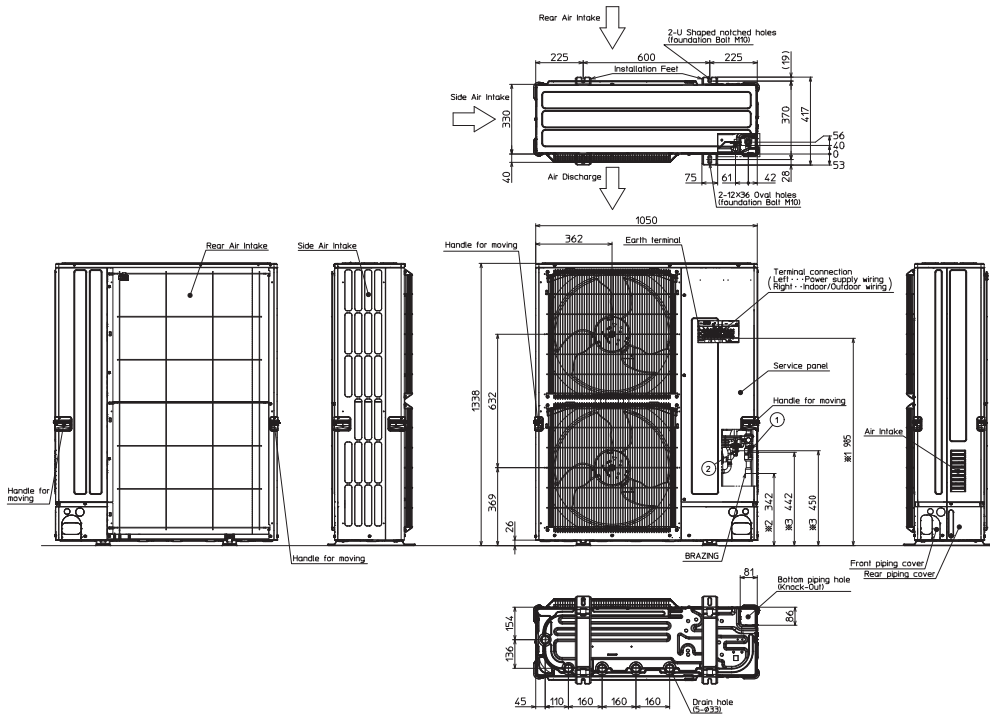

PUHZ-SHW230YKA2

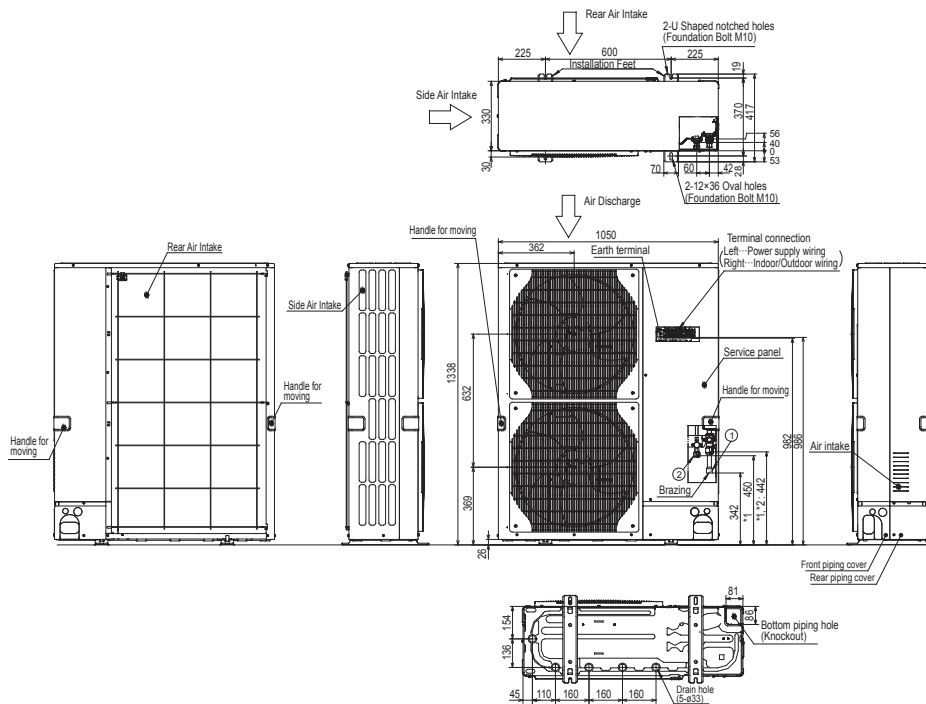

PUZ-WZ

Unit : mm

- PUZ-WZ90VAA
- PUZ-WZ90YAA
- PUZ-WZ115VAA
- PUZ-WZ115YAA
- PUZ-WZ140VAA
- PUZ-WZ140YAA

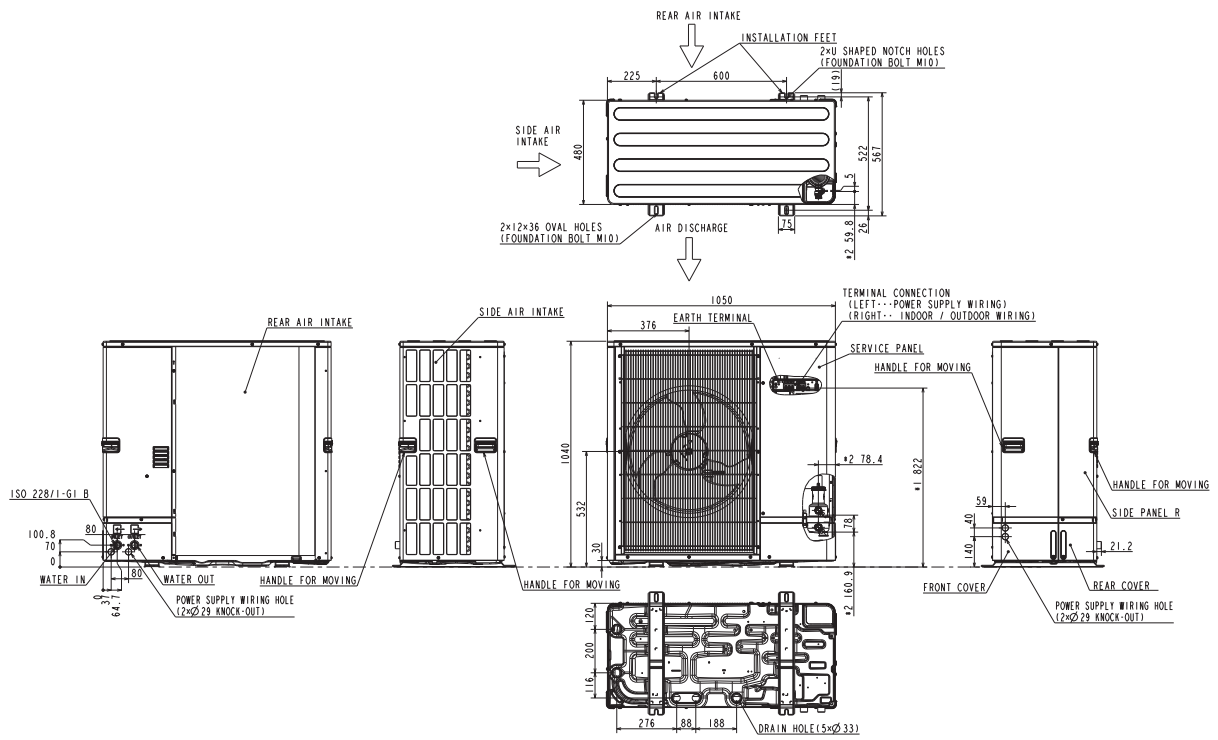

# Indoor Unit

## HYDROTANK

### Packaged model

DHW tank capacity	170L	200L	300L
①	1400	1600	2050
②	456	456	931

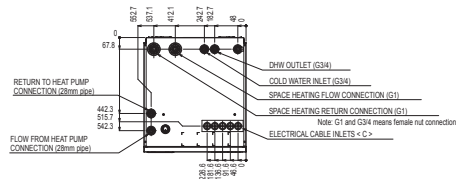

<E\*PT30X-\*M\*EE>

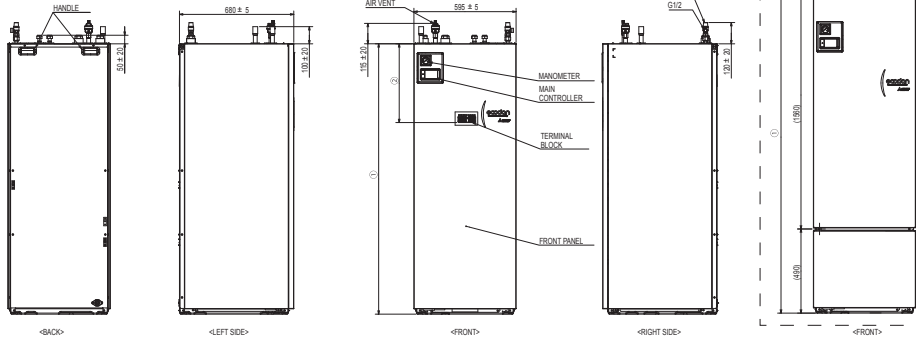

### Split model

DHW tank capacity	170L	200L	300L
①	1400	1600	2050
②	456	456	931

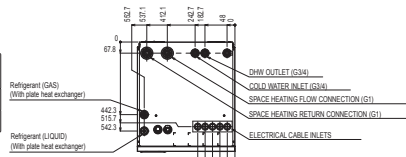

<E\*ST30\*-\*M\*EE>

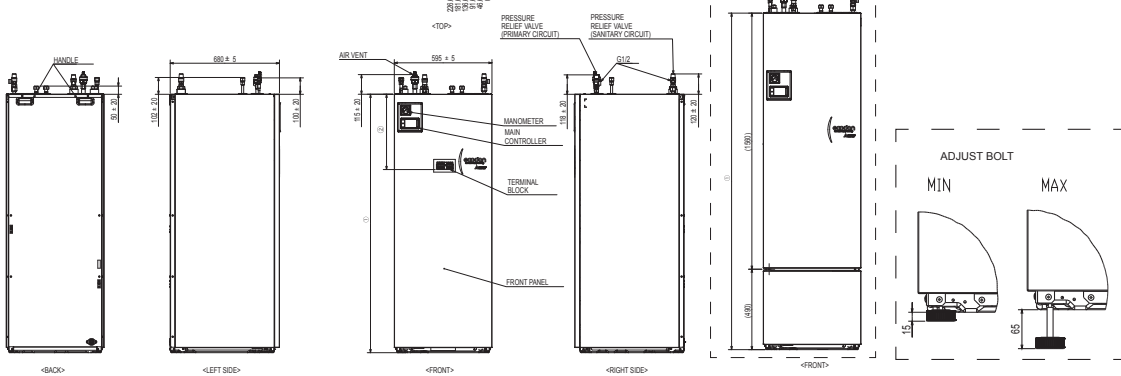

Pipe description	Connection size/type	
Refrigerant (GAS) (With plate heat exchanger)	12.7 mm or 15.88 mm/Flare (E*ST**F-*) 12.7 mm/Flare (E*ST**D-*) 15.88 mm/Flare (E*ST**C-*)	<b>Warning</b> • Refrigerant pipes connection shall be accessible for maintenance purposes. • In case of reconnecting the refrigerant pipes after detaching, make the flared part of pipe re-fabricated.
Refrigerant (LIQUID) (With plate heat exchanger)	6.35 mm/Flare (E*ST**F/D-*) 9.52 mm/Flare (E*ST**C-*)	
Electrical cable inlets ① ② ③ ④ ⑤	For inlets ① ② ③, run low-voltage wires including external input wires and thermistor wires. For inlets ④ ⑤, run high-voltage wires including power cable, indoor-outdoor cable, and external output wires. For a wireless receiver (option) cable and ecodan Wi-Fi interface (option) cable, use inlet ①.	

# HYDROBOX

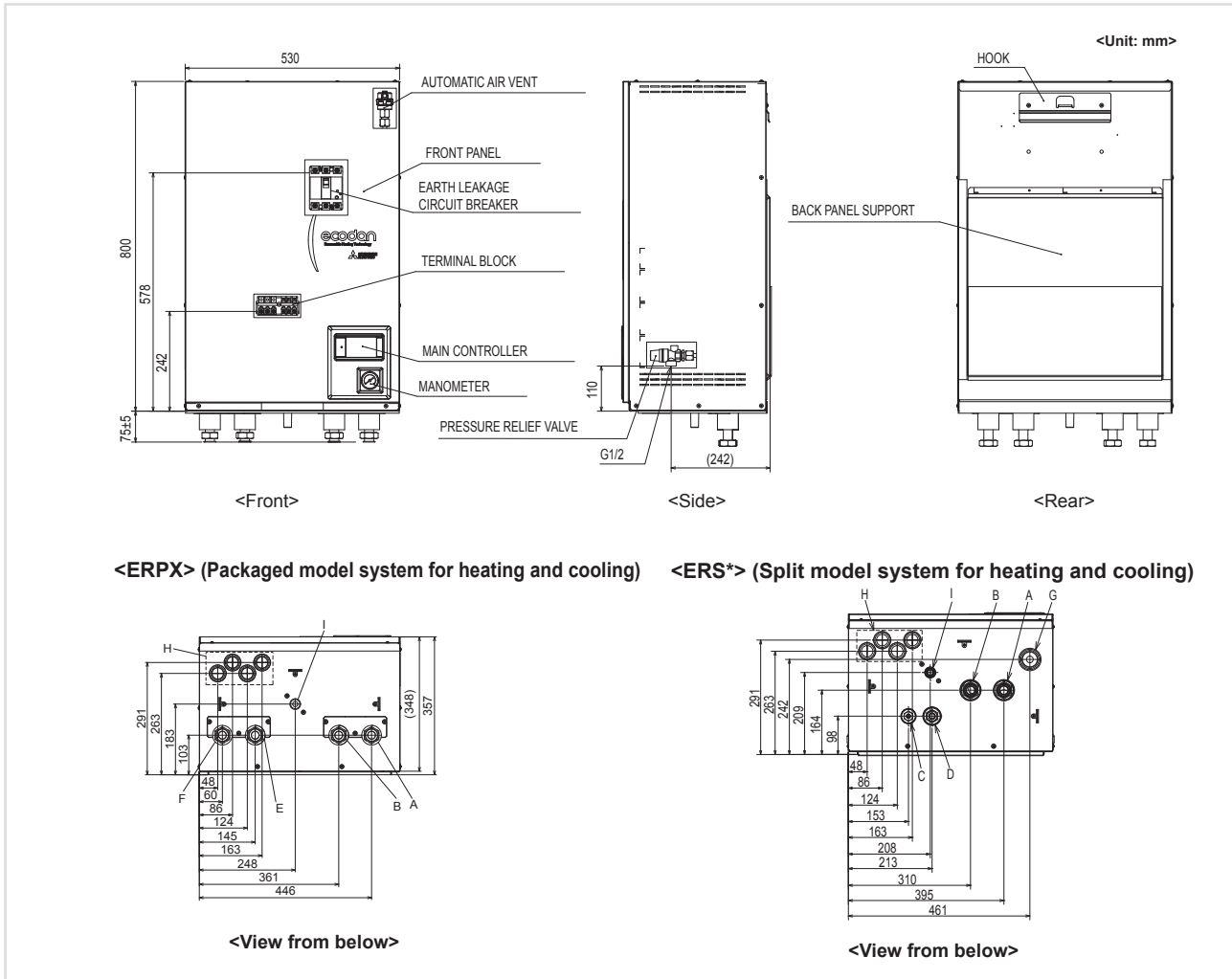

Letter	Pipe description	Connection size/type	
A	Space heating/Indirect DHW tank (primary) RETURN connection	G1 (EHSD/ERSD/ERSC/ERSF/ERPX-*)	
B	Space heating/Indirect DHW tank (primary) FLOW connection	G1 (EHSD/ERSD/ERSC/ERSF/ERPX-*)	
C	Refrigerant (Liquid)	6.35 mm/Flare (E*SD/F-*) 9.52 mm/Flare (E*SC-*)	<b>⚠ Warning</b> • Refrigerant pipes connection shall be accessible for maintenance purposes. • In case of reconnecting the refrigerant pipes after detaching, make the flared part of pipe re-fabricated.
D	Refrigerant (Gas)	12.7 mm/Flare (E*SD-*) 12.7 or 15.88mm/Flare (ERSF-*) 15.88 mm/Flare (E*SC-*)	
E	Flow connection FROM heat pump	G1 (ERPX-*)	
F	Return connection TO heat pump	G1 (ERPX-*)	
G	Discharge pipe (by installer) from pressure relief valve	G1/2 (valve port within hydrobox casing)	
H	Electrical cable inlets ① ② ③ ④	For inlets ① ②, run high-voltage wires including power cable, indoor-outdoor cable, and external output wires. For inlets ③ ④, run low-voltage wires including external input wires and thermistor wires. * For a wireless receiver (option) cable, use inlet ④.	
I	Drain socket	Outside diameter 20 mm (EHSD-* not included.)	

<ERSE> (Split model system for heating and cooling)

<Unit: mm>

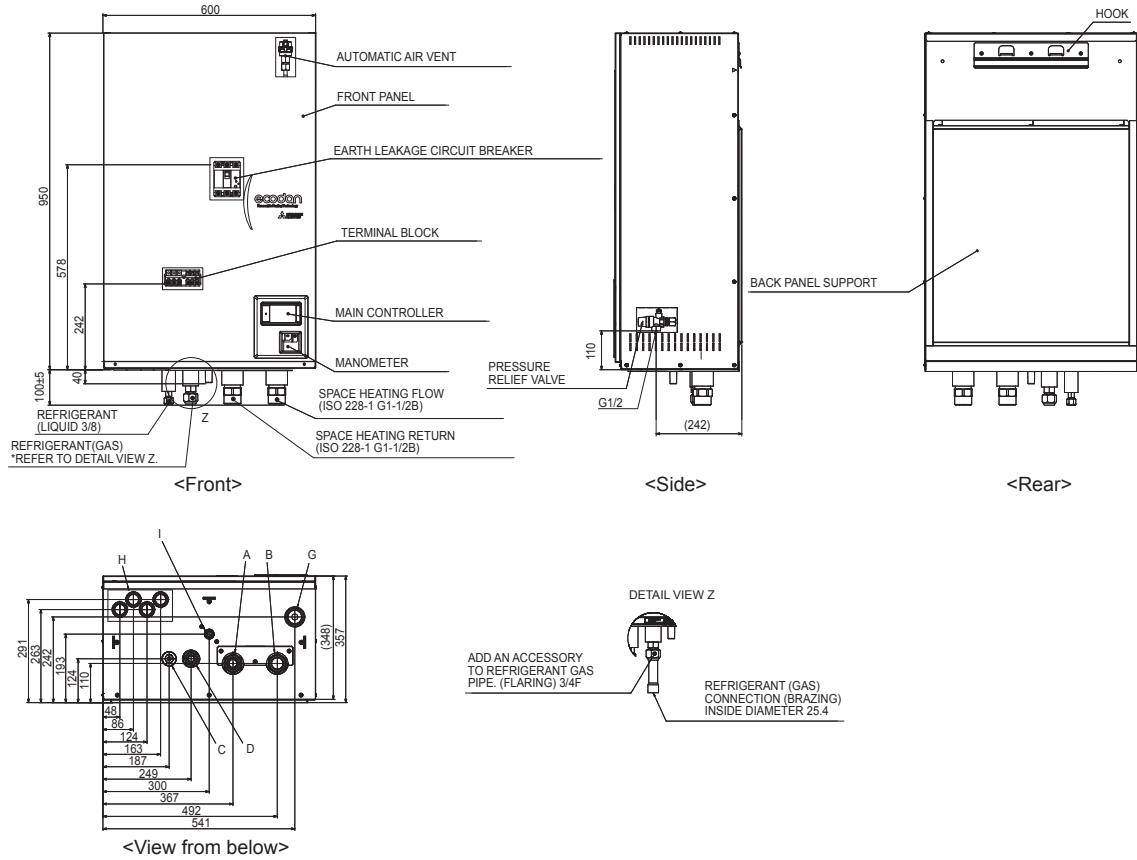

Letter	Pipe description	Connection size/type
A	Space heating/Indirect DHW tank (primary) RETURN connection	G1-1/2B (ERSE-*)
B	Space heating/Indirect DHW tank (primary) FLOW connection	G1-1/2B (ERSE-*)
C	Refrigerant (Liquid)	9.52 mm/Flare (ERSE-*)
D	Refrigerant (Gas)	Inside diameter 25.4 mm (ERSE-*)
G	Discharge pipe (by installer) from pressure relief valve	G1/2 (valve port within hydrobox casing)
H	Electrical cable inlets ① ② ③ ④	For inlets ① ②, run high-voltage wires including power cable, indoor-outdoor cable, and external output wires. For inlets ③ ④, run low-voltage wires including external input wires and thermistor wires. * For a wireless receiver (option) cable, use inlet ④.
I	Drain socket	Outside diameter 20 mm (EHSD-* not included.)

**⚠ ATTENZIONE**

- Le connessioni frigorifere devono essere accessibili per manutenzione.
- In caso di ricollegamento dei tubi del refrigerante dopo lo smontaggio, rilavorare la parte svasata del tubo.

# DHWTANK

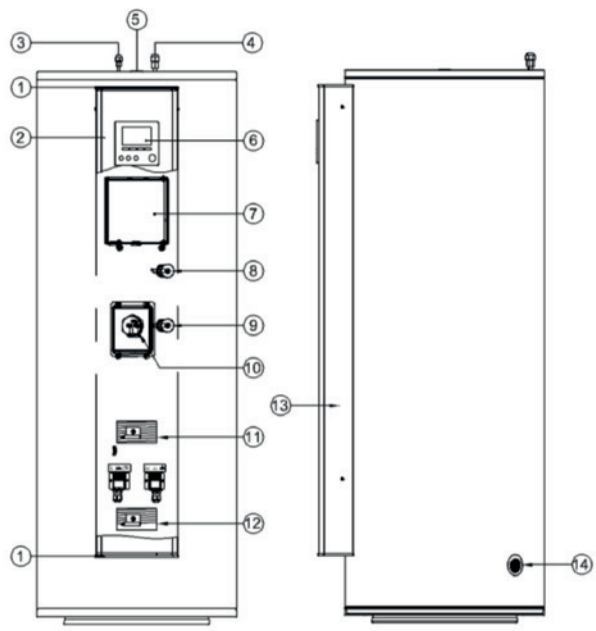
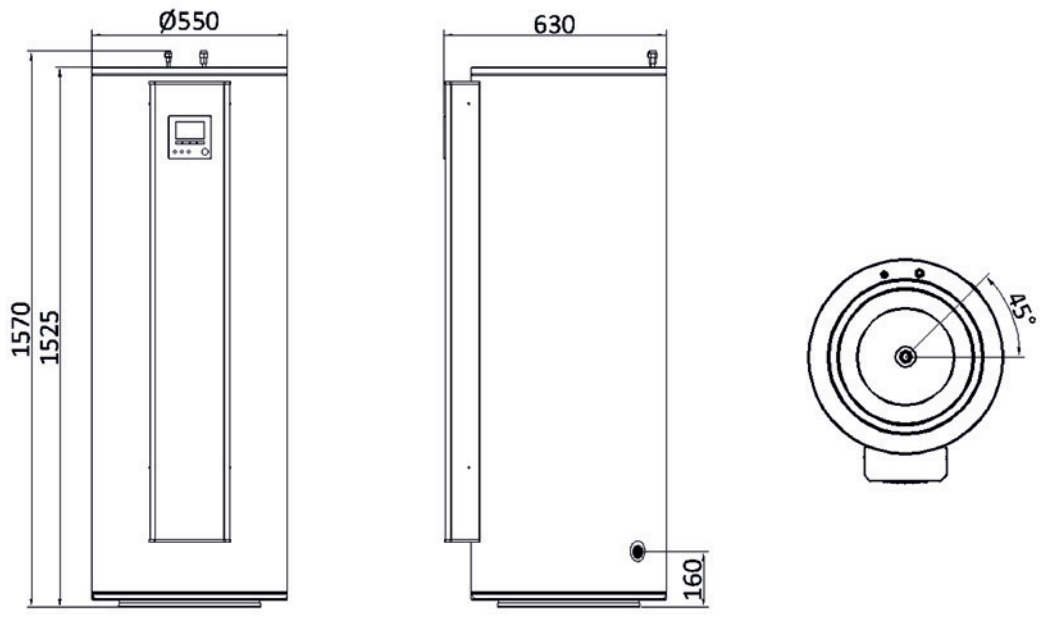

1	Plastic Cover
2	Metallic Front Cover
3	Refrigerant connection (liquid line) $\frac{1}{4}$ " $\varnothing 6,35$ mm
4	Refrigerant connection (gas line) $\frac{3}{8}$ " $\varnothing 9,52$ mm
5	Hot Water (outlet) connection - $\frac{3}{4}$ " F
6	Main remote controller (HMI)
7	PCB
8	Upper Water thermistor THW5
9	Lower Water thermistor THW5A
10	Immersion Heater 1,5kW 230V 1 $\frac{1}{4}$ "
11	Refrigerant thermistor TH5
12	Refrigerant thermistor TH2
13	Metallic Front Cover
14	Cold water (inlet) connection - $\frac{3}{4}$ " F (rotate 45°)



# Water circulation pump characteristics

## HYDROTANK

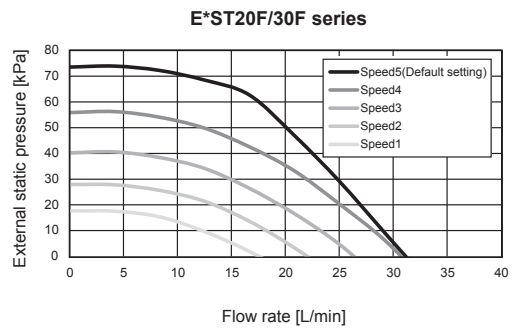
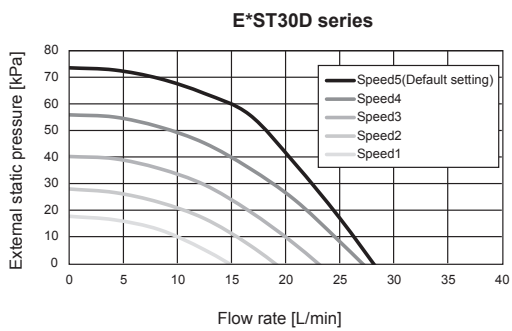
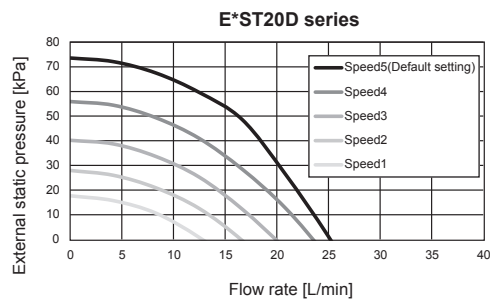
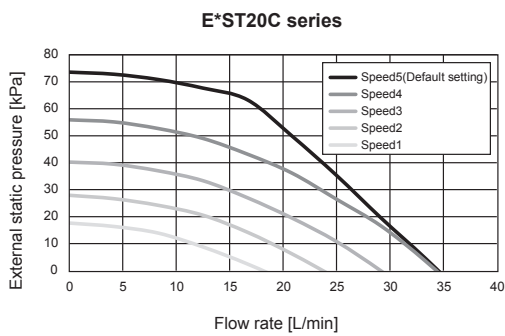
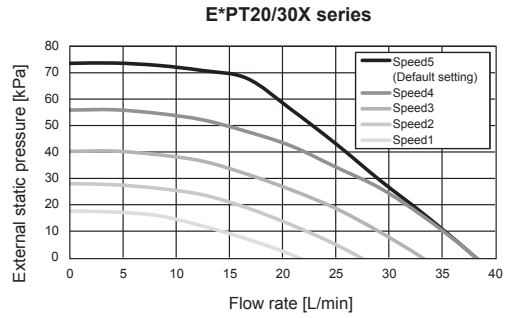
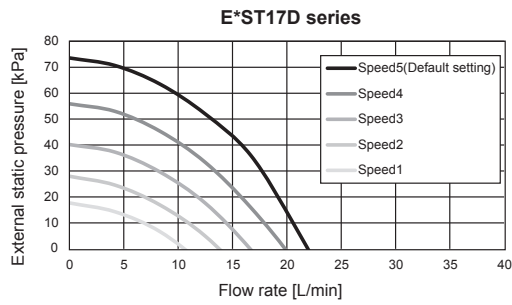

# HYDROBOX

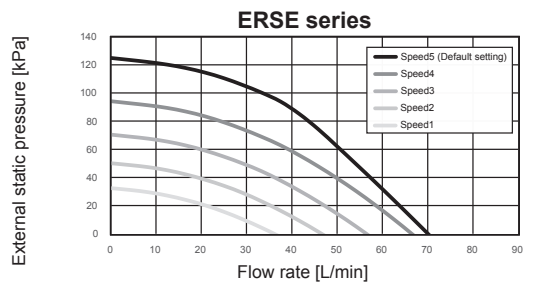
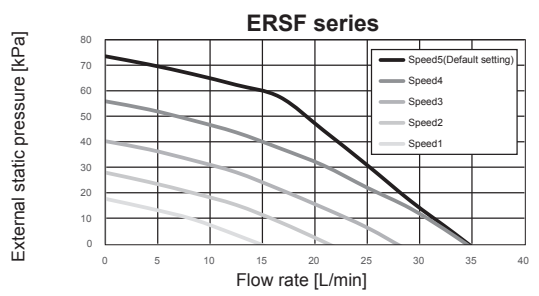
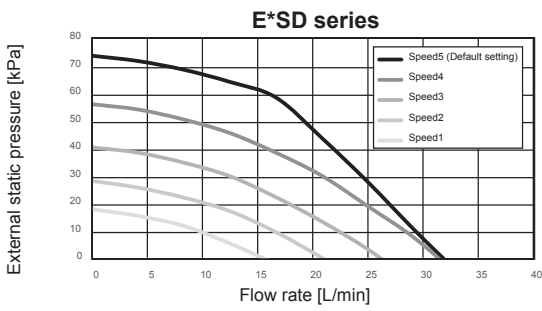
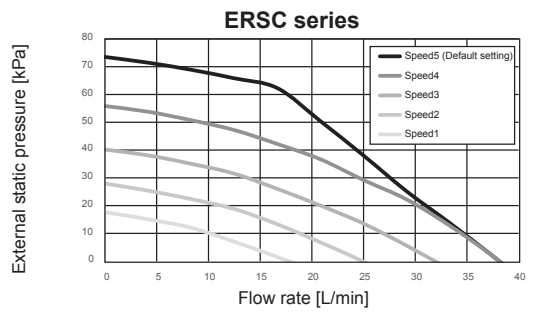
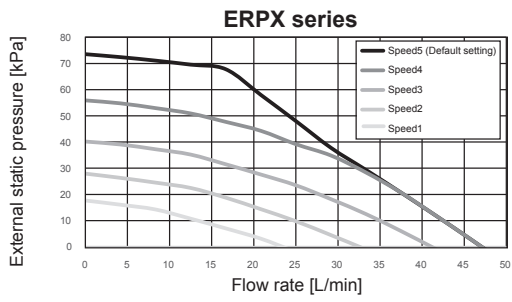

## Water flow rate range

Outdoor heat pump unit		Water flow rate range [L/min]	Recommended flow [L/min]* <sup>1</sup>
Packaged model	PUZ-WZ90VAA	7,2 - 27,2	14,3
	PUZ-WZ115VAA/YAA	7,2 - 27,2	14,3
	PUZ-WZ140YAA	10,0 - 34,4	21,5
Split model	SUZ-SWM40VA2	6.5 - 11.4	7,2
	SUZ-SWM60VA2	7.2 - 17.2	10,8
	SUZ-SWM80VA2	10.8 - 21.5	13,4
	SUZ-SWM100VA	10.8 - 25.8 <sup>*3</sup>	16,1
	PUZ-S(H)WM80VAA	7.2 - 22.9	14,3
	PUZ-S(H)WM100VAA/YAA	7.2 - 28.7	17,9
	PUZ-S(H)WM120VAA/YAA	10.0 - 34.4 <sup>*3</sup>	21,5 <sup>*2</sup>
	PUZ-S(H)WM140VAA/YAA	10.0 - 34.4 <sup>*3</sup>	25,1 <sup>*2</sup>
	PUHZ-SW160YKA	23.0 - 61.5	28,7
	PUHZ-SW200YKA	28.7 - 61.5	35,8
	PUHZ-SHW230YKA2	28.7 - 61.5	41,2 <sup>*2</sup>
Multi model	PXZ-4F75VG/VG2	11.5 - 21.7	13,4
	PXZ-5F85VG/VG2	11.5 - 24.6 <sup>*3</sup>	15,2
	PUMY-P112	17.9 - 35.8 <sup>*3</sup>	25,1 <sup>*2</sup>
	PUMY-P125	17.9 - 35.8 <sup>*3</sup>	28,7 <sup>*2</sup>
	PUMY-P140	17.9 - 35.8 <sup>*3</sup>	29,6 <sup>*2</sup>

If the water flow rate is less than the minimum flow rate setting of the flow sensor (default 5.0 L/min), the flow rate error will be activated.

If the water flow rate exceeds 36.9 L/min (E\*\*T20/30 series) or 25.8 L/min (E\*\*T17 series), the flow speed will be greater than 2.0 m/s, which could erode the pipes.

\*<sup>1</sup> To ensure optimal heating operation (condition: inlet/outlet temperature difference  $\Delta T = 8K$ ).

\*<sup>2</sup> With buffer tank

\*<sup>3</sup> If you want to secure the maximum flow rate, please install an additional pump.

## Minimum amount of water required in the space heating/cooling circuit

Outdoor heat pump unit		Indoor unit containing water amount [L]	Additional required water amount [L]	
			Average / Warmer climate* <sup>1</sup>	Colder climate* <sup>1</sup>
Packaged model	PUZ-WZ90VAA	5	7	44
	PUZ-WZ115VAA/YAA	5	8	47
	PUZ-WZ140YAA	5	12	64
Split model	SUZ-SWM40VA2	5	5* <sup>1</sup>	12* <sup>1</sup>
	SUZ-SWM60VA2	5	9* <sup>1</sup>	21* <sup>1</sup>
	SUZ-SWM80VA2	5	12* <sup>1</sup>	29* <sup>1</sup>
	SUZ-SWM100VA	5	12* <sup>1</sup>	38* <sup>1</sup>
	PUZ-S(H)WM80VAA	5	6	29
	PUZ-S(H)WM100VAA/YAA	5	9	38
	PUZ-S(H)WM120VAA/YAA	5	12	47
	PUZ-S(H)WM140VAA/YAA	5	15	55
	PUHZ-SW160YKA	5	18	64
	PUHZ-SW200YKA	5	24	81
	PUHZ-SHW230YKA2	5	28	94
Multi model	PXZ-4F75VG/VG2	5	6	27
	PXZ-5F85VG/VG2	5	6	29
	PUMY-P112	5	22	75
	PUMY-P125	5	22	75
	PUMY-P140	5	22	75

\*1 Climate: Please refer to 2009/125/EC: Energy-related Products Directive and Regulation (EU) No 813/2013 to confirm your climate zone.

\*2 SUZ series: Flow temperature MUST always be NO lower than 32 °C when outdoor temperature drops below -15 °C. Potential risks of plate HEX get frozen and damaged, and also outdoor HEX would be frosted due to insufficient defrosting.

 **NOTICE**

Our air-conditioning equipments and heat pumps contain a fluorinated greenhouse gas, R290 (GWP: <3), R410A (GWP: 2088) or R32 (GWP: 675). \*These GWP values are based on Regulation (EU) No.517/2014 from IPCC 4th edition. In case of Regulation (EU) No.626/2011 from IPCC 3rd edition, these are as follows. R290 (GWP: 0.02), R410A (GWP: 1975), R32 (GWP: 550)

 **CAUTION**

Do not install indoor units in areas (e.g. mobile phone base stations) where the emission of VOCs such as phthalate compounds and formaldehyde is known to be high as this may result in a chemical reaction.

 **WARNING**

When installing or relocating or servicing our air-conditioning equipment, use only the specified refrigerant (R290, R410A or R32) to charge the refrigerant lines.

Do not mix it with any other refrigerant and do not allow air to remain in the lines.

If air is mixed with the refrigerant, then it can be the cause of abnormal high pressure in the refrigerant lines, and may result in an explosion and other hazards.

The use of any refrigerant other than that specified for the system will cause mechanical failure, system malfunction or unit breakdown. In the worst case, this could lead to a serious impediment to securing product safety.

## MITSUBISHI ELECTRIC CORPORATION

HEAD OFFICE: TOKYO BUILDING, 2-7-3 MARUNOUCHI, CHIYODA-KU, TOKYO 100-8310, JAPAN  
<https://www.mitsubishielectric.com/>

Air to Water Catalogue  
E-2604260 (19268)



E-2604260



Revised publication effective Mar. 2025.  
Superseding publication of S-179-2-CA762-E Sep. 2024.  
Specifications are subject to change without notice.